

STRATEO

TRIPLE SERVICE SPLIT INVERTER AIR-TO-WATER HEAT PUMPS WITH ELECTRICAL BACK-UP: HEATING, COOLING AND DOMESTIC HOT WATER



AWHP 4.5 MR
AWHP 6 MR
AWHP 8 MR



mic indoor module
(with integrated 190-litre tank)



hydraulic connection plate for pre-assembly

- **STRATEO ...MR/E 1C:**
from 4.5 to 8 kW for 1 circuit (single-phase operation with back-up via integrated immersion heater).

- **STRATEO ...MR/E 2C:**
from 4.5 to 8 kW for 2 circuits (single-phase operation with back-up via integrated immersion heater).



Heating only by radiators, heating and cooling by underfloor heating/cooling or air conditioning by convection fans, production of domestic hot water



Air-to-water heat pump



Electricity (energy supplied to the compressor)



Free, natural and renewable energy

OPERATING CONDITIONS

operating temperature limits

in heating mode

- Outside air: - 20/+ 35 °C (- 15/+ 35 °C for 4.5 and 6 MRI)
- Water: + 18/+ 60 °C (55 °C for 4.5 kW)

in cooling mode

- Outside air: + 7/+ 46 °C
- Water: + 18/+ 25 °C

in air conditioning mode

- Outside air: + 7/+ 46 °C
- Water: + 7/+ 25 °C

Heating circuit

Max. operating pressure: 3 bar
Max. operating temp.: 75 °C

DHW circuit

Max. operating pressure: 10 bar
Max. operating temp.: 65 °C

The STRATEO is the silent, effective heat pump solution for new buildings. It is characterised by its compact size and efficient performance: COP of up to 5.11 at an outdoor air temperature of + 7 °C.

A high-tech product with an INVERTER system with power accumulator, the STRATEO heat pump offers a more stable setpoint temperature, substantially reduced power consumption and quiet operation, generating a sound power level of just 30 dB(A) to 39 dB(A). The reversible STRATEO also operates in cooling mode via the underfloor cooling system (water at + 18 °C), and as air conditioning via convection fans (EER of 3.96 to 4.75 for an outdoor temperature of + 35 °C).

With its compact dimensions, it is easy to install thanks to its wall-mounted pre-assembly plate for the hydraulic connections. The hydraulic unit integrating all the elements required for the heating installation can be accessed behind the front panel, which facilitates maintenance. It includes a 190-litre DHW tank located under the indoor unit in the form of an attractive uniform column. It offers optimal comfort all year round. Its compact construction, design and simple installation mean it can be easily integrated in a new build environment.



certificates available on:
<https://www.eurovent-certification.com/>

PRESENTATION OF THE RANGE

STRATEO

ADVANTAGES

NEW CONTROL SYSTEM

- Connected intuitive control system with clear text
- New bluetooth function with smartphone application to aid set-up
- The control panel on the MIC modules enables the entire system to be managed by providing an interface between the outdoor unit and the DHW production and heating system.

DESIGN

- Eco-designed to ensure maximum respect for the environment
- Packaging made entirely from cardboard
- Exceptional RT2012 and "RE 2020 READY" performances
- Excellent acoustic comfort below the Cerqual/Qualitel HQE level at just 30 dB[A] for the 4.5 kW model

COMPACT

- Compact and easy to integrate with a 560 mm x 586 mm footprint, and a height of 1950 mm
- Includes a built-in 190-litre enamelled tank, equipped with a magnesium anode
- Option to install in a standard size cupboard
- Can be integrated into a living room



ACCESS TO THE INDOOR UNIT COMPONENTS

- Equipped with all the safety components required for operation: valve with filter, stop valves, motorised DHW reversing valve, 7-bar DHW valve, non-return valve, disconnect
- All the heating elements for the indoor unit can be accessed from the front panel.
- Reinforced protection with integrated magnetic sludge filter

EXPERTISE BUILT INTO A HEAT PUMP

- Two-stage assembly with the new pre-equipped connection plate (stop valves, box with siphon)
- Available ex works in 1-circuit or 2-circuit heating versions
- Can be delivered in separate packages on request

EASY TO ASSEMBLE

- Installation times reduced thanks to the pre-assembly plate which enables all the circuits (DHW, heating and cooling) to be connected up hydraulically during the site works phase. Equipped with the stop valves, 2 cooling lines, a collector box and siphon
- Castor wheels ensure the indoor unit is easy to position
- Installation and commissioning aids: fitting jig, quick guide, interactive control



Twice as compact

.....

Twice as quiet

.....

Two hours quicker to install

PRESENTATION OF THE RANGE

STRATEO







THE VARIOUS MODELS AVAILABLE

Reversible air-to-water heat pump for outdoor temperatures down to -20 °C (-15 °C for 4.5 and 6 kW versions).
For heating by radiators or heating and cooling by underfloor heating/cooling or air conditioning by convection fans.
Back-up via a built-in 3 kW immersion heater.

VERSION FOR 1 HEATING CIRCUIT

EASYLIFE









MODELS	REFERENCE	MIC-1C V190 INDOOR UNIT	OUTDOOR UNIT			1-CIRCUIT HYDRAULIC CONNECTION PLATE	REFRIGERANT ADAPTOR CONNECTION
							
			AWHP 4.5 MR	AWHP 6 MR	AWHP 8 MR		
STRATEO 4.5 MR/E 1C	7728542	7700833	7656794	—	—	7696865	100015480
STRATEO 6 MR/E 1C	7728543	7700833	—	7668016	—	7696865	100015480
STRATEO 8 MR/E 1C	7728544	7700833	—	—	7609926	7696865	—

(1) Water temp. at outlet: +35 °C, outdoor temp.: +7 °C
(2) Water temp. at outlet: +18 °C, outdoor temp.: +35 °C

VERSION FOR 2 HEATING CIRCUITS

EASYLIFE



MODELS	REFERENCE	MIC-2C V190 INDOOR UNIT	OUTDOOR UNIT			2-CIRCUIT HYDRAULIC CONNECTION PLATE	REFRIGERANT ADAPTOR CONNECTION
							
			AWHP 4.5 MR	AWHP 6 MR	AWHP 8 MR		
STRATEO 4.5 MR/E 2C	7728545	7718118	7656794	—	—	7716971	100015480
STRATEO 6 MR/E 2C	7728546	7718118	—	7668016	—	7716971	100015480
STRATEO 8 MR/E 2C	7728547	7718118	—	—	7609926	7716971	—

(1) Water temp. at outlet: +35 °C, outdoor temp.: +7 °C
(2) Water temp. at outlet: +18 °C, outdoor temp.: +35 °C

TECHNICAL SPECIFICATIONS

STRATEO

TECHNICAL SPECIFICATIONS

OPERATING CONDITIONS: OPERATING TEMPERATURE LIMITS

In heating mode:

Water: + 18 °C/+ 60 °C, (+ 55 °C for 4.5 kW)

Outside air: - 20 °C/+ 35 °C (- 15 °C for 4.5 and 6 MR/E)

In cooling mode:

Water: + 18 °C/+ 25 °C,

Outside air: + 7 °C/+ 46 °C

In air conditioning mode:

Water: + 7 °C/+ 25 °C,

Outside air: + 7 °C/+ 46 °C

MODEL

MODEL	STRATEO	4.5 MR/EM	6 MR/EM	8 MR/EM
Heat output at +7 °C/+35 °C (1)	kW	4.60	5.82	7.65
Heating COP at +7 °C/+35 °C (1)		5.11	4.22	4.55
Absorbed electrical power at +7 °C/+35 °C (1)	kWe	0.90	1.38	1.68
Heat output at +2 °C/+35 °C (1)	kW	3.47	3.74	6.75
Heating COP at +2 °C/+35 °C (1)		3.97	3.37	3.43
Heat output at -7 °C/+35 °C (1)	kW	2.79	3.96	5.56
Heating COP at -7 °C/+35 °C (1)		3.07	2.59	2.78
Cooling output at +35 °C/+18 °C (2)	kW	4.12	5.08	7.91
Cooling COP at +35 °C/+18 °C (2)		4.32	4.20	4.27
Absorbed electrical power at +35 °C/+18 °C (2)	kWe	0.95	1.15	1.85
Cooling output at +35 °C/+7 °C (5)	kW	4.52	4.50	6.39
Cooling COP at +35 °C/+7 °C (5)		2.77	2.65	2.85
Seasonal energy efficiency (SEE) in heating mode at 55 °C	%	125	126	126
Nominal water flow rate at $\Delta t = 5$ K	m ³ /h	0.80	1.00	1.32
Total dynamic head at nominal flow rate at $\Delta t = 5$ K	mbar	650	550	300
Power supply voltage of the outdoor unit	V	230 V single-phase	230 V single-phase	230 V single-phase
Start-up amperage	A	5	5	5
Outdoor/indoor module sound power (4)	dB(A)	55/30	62/39	66/39
Indoor/outdoor module perceived sound level (7)	dB(A)	33/22	40/31	44/31
DHW tank capacity	L	190	190	190
Max. usable hot water volume (Vmax) (6)	L	275	275	277
Heating time (th) (6)	h	1h40	1h40	1h15
Power absorbed at stabilised rate (Pes) (6)	W	21.4	32.6	35.5
COP_DHW (M/L draw-off cycle)		2.80/3.20	2.70/3.20	2.50/2.90
DHW seasonal energy efficiency	%	118/133	117/130	107/123
Refrigerant fluid R410A	kg	1.3	1.4	3.2
Refrigerant connection (Liquid/Gas)	inches	1/4-1/2	1/4-1/2	3/8-5/8
CO ₂ equivalent	tonne	2.71	2.92	6.68
Max. pre-loaded length	m	7	10	10
Water content	L	5	5	5
Outdoor unit weight	kg	63	47	82.2
Indoor unit/hydraulic plate weight (1C)	kg	176.5/12.5	176.5/12.5	176.5/12.5
Indoor unit/hydraulic plate weight (2C)	kg	188/13.5	188/13.5	188/13.5

(1) Heating mode: outside air temp./water temp. at outlet, performance in accordance with EN 14511-2.

Performance in accordance with EN 14511-2 with optimised inverter frequency.

(2) Cooling mode: outdoor air temp./water temp. at the outlet, performance according to EN 14511-2.

(4) Test performed in accordance with standard EN 12102, at + 7 °C/+ 55 °C.

(5) Air conditioning mode: outdoor air temp./water temp. at the outlet, performance according to EN 14511-2.

(6) Draw-off cycle M in accordance with EN 16147

(7) at 1 m in a free field (5 m for the outdoor unit)

* At average temperature.

RT2012 data

Refer to the RT input sheet available online:

https://pro.dedietrich-thermique.fr/site_pro

TEMPERATURE OF THE WATER PRODUCED

STRATEO heat pump models can produce hot water up to 60 °C (55 °C for 4.5 kW version). The graph shows the water temperatures produced based on the outdoor temperature.

STRATEO 4.5 MR/E...

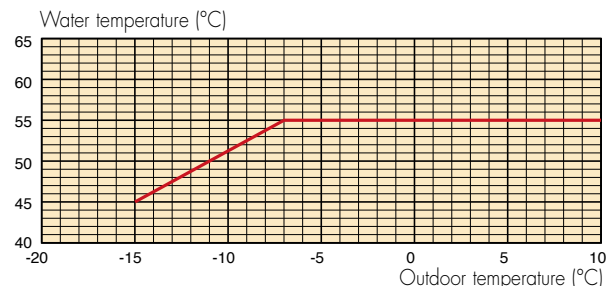

STRATEO 6 MR/E...

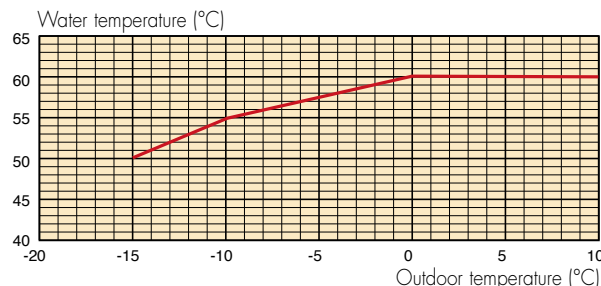

STRATEO 8 MR/E...

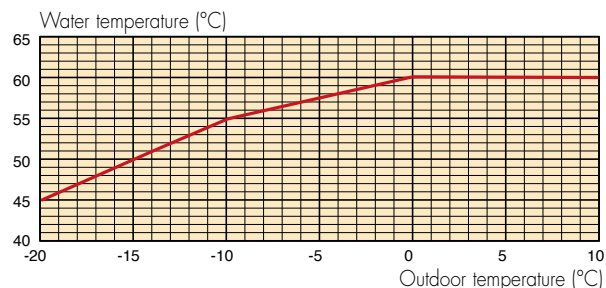

HPI 10047

TECHNICAL SPECIFICATIONS

STRATEO

TABLE OF DATA FOR SIZING

4.5 MR/E

		WATER OUTLET TEMPERATURE (°C)																	
		COOLING								HEATING									
		7		18		25		35		40		45		50		55		60	
OUTSIDE AIR TEMP. (°C)	Output (kW)	COP	Output (kW)	COP	Output (kW)	COP	Output (kW)	COP	Output (kW)	COP	Output (kW)	COP	Output (kW)	COP	Output (kW)	COP	Output (kW)	COP	
	-20	—	—	—	—	—	—	—	—	—	—	—	—	—	—	—	—	—	—
	-15	—	—	—	—	3.73	2.53	3.41	2.17	3.27	1.71	3.1	1.63	—	—	—	—	—	—
	-10	—	—	—	—	4.38	2.98	4.03	2.27	3.86	2	3.69	1.77	3.52	1.57	—	—	—	—
	-7	—	—	—	—	4.7	3.13	4.4	2.46	4.21	2.16	4.02	1.91	3.74	1.61	3.5	1.34	—	—
	2	—	—	—	—	3.5	3.52	3.5	3.04	3.5	2.8	3.5	2.55	3.5	2.23	3.5	1.91	—	—
	7	—	—	—	—	4.5	6.42	4.5	5.06	4.5	4.38	4.5	3.7	4.5	3.2	4.5	2.7	—	—
	12	—	—	—	—	5.08	7.45	5.08	5.84	5.08	5.03	5.08	4.22	5.08	3.6	5.08	2.99	—	—
	15	—	—	—	—	5.42	8.07	5.42	6.3	5.42	5.42	5.42	4.54	5.42	3.85	5.42	3.16	—	—
	20	5.3	3.13	7.1	3.54	6	8.19	6	7.08	6	6.07	6	5.06	6	4.25	6	3.45	—	—
25	5.3	3.16	7.1	3.73	—	—	—	—	—	—	—	—	—	—	—	—	—	—	
30	5.1	2.82	6.8	3.39	—	—	—	—	—	—	—	—	—	—	—	—	—	—	
35	4.9	2.48	6.5	2.99	—	—	—	—	—	—	—	—	—	—	—	—	—	—	

6 MR/E

		WATER OUTLET TEMPERATURE (°C)																	
		COOLING								HEATING									
		7		18		25		35		40		45		50		55		60	
OUTSIDE AIR TEMP. (°C)	Output (kW)	COP	Output (kW)	COP	Output (kW)	COP	Output (kW)	COP	Output (kW)	COP	Output (kW)	COP	Output (kW)	COP	Output (kW)	COP	Output (kW)	COP	
	-20	—	—	—	—	—	—	—	—	—	—	—	—	—	—	—	—	—	—
	-15	—	—	—	—	—	—	3.80	2.04	3.42	1.76	3.04	1.48	2.66	1.20	—	—	—	—
	-10	—	—	—	—	5.60	2.97	4.86	2.42	4.49	2.14	4.13	1.87	4.00	1.69	3.87	1.51	—	—
	-7	—	—	—	—	6.22	3.20	5.50	2.65	5.14	2.38	4.78	2.10	4.63	1.90	4.48	1.70	—	—
	2	—	—	—	—	5.00	3.47	5.00	2.97	5.00	2.72	5.00	2.47	5.00	2.22	5.00	1.97	5.00	1.72
	7	—	—	—	—	5.50	5.52	5.50	4.42	5.50	3.87	5.50	3.32	5.50	2.77	5.50	2.22	5.50	1.67
	12	—	—	—	—	6.41	6.46	6.41	5.18	6.41	4.53	6.41	3.89	6.41	3.24	6.41	2.60	6.41	1.96
	15	—	—	—	—	6.96	7.03	6.96	5.63	6.96	4.93	6.96	4.23	6.96	3.53	6.96	2.83	6.96	2.13
	20	4.9	3.48	5.4	5.44	7.87	7.98	7.87	6.39	7.87	5.59	7.87	4.80	7.87	4.00	7.87	3.21	7.87	2.41
25	4.9	3.52	5.4	5.74	—	—	—	—	—	—	—	—	—	—	—	—	—	—	
30	4.7	3.14	5.2	5.21	—	—	—	—	—	—	—	—	—	—	—	—	—	—	
35	4.5	2.76	5	4.6	—	—	—	—	—	—	—	—	—	—	—	—	—	—	

8 MR/E

		WATER OUTLET TEMPERATURE (°C)																	
		COOLING								HEATING									
		7		18		25		35		40		45		50		55		60	
OUTSIDE AIR TEMP. (°C)	Output (kW)	COP	Output (kW)	COP	Output (kW)	COP	Output (kW)	COP	Output (kW)	COP	Output (kW)	COP	Output (kW)	COP	Output (kW)	COP	Output (kW)	COP	
	-20	—	—	—	—	—	—	4.52	2.03	4.55	1.86	4.23	1.64	—	—	—	—	—	—
	-15	—	—	—	—	—	—	5.40	2.32	5.33	2.09	5.25	1.87	3.97	1.28	—	—	—	—
	-10	—	—	—	—	8.05	2.72	7.69	2.35	7.51	2.11	7.33	1.88	6.82	1.72	6.29	1.56	—	—
	-7	—	—	—	—	8.93	3.28	8.42	2.77	8.21	2.45	7.99	2.13	7.43	1.94	7.00	1.74	—	—
	2	—	—	—	—	7.50	3.97	7.50	3.40	7.50	3.11	7.50	2.83	7.50	2.37	7.14	1.91	6.57	1.65
	7	—	—	—	—	8.00	5.24	8.00	4.40	8.00	3.90	8.00	3.40	8.00	3.10	8.00	2.77	8.00	2.33
	12	—	—	—	—	9.00	6.16	9.00	5.26	9.00	4.54	9.00	3.83	9.00	3.42	9.00	2.97	9.00	2.50
	15	—	—	—	—	9.65	6.63	9.65	5.70	9.65	4.87	9.65	4.04	9.65	3.59	9.65	3.11	9.65	2.58
	20	8.50	3.60	11.30	4.38	10.15	7.03	10.15	6.03	10.15	5.14	10.15	4.25	10.15	3.76	10.15	3.25	10.15	2.68
25	8.20	3.26	11.00	4.05	—	—	—	—	—	—	—	—	—	—	—	—	—	—	
30	7.80	2.89	10.60	3.67	—	—	—	—	—	—	—	—	—	—	—	—	—	—	
35	7.30	2.55	10.00	3.18	—	—	—	—	—	—	—	—	—	—	—	—	—	—	

These performance ratings are not certified, but they must only be used to size the heat pump.

For sizing, we recommend using the AWHP table available on the site:

http://pro.dedietrich-thermique.fr/fr/site_pro/logiciels/diomasoft/diematools_la_boite_a_outils

TECHNICAL SPECIFICATIONS

STRATEO

STRATEO heat pumps comprise an outdoor unit (see p. 10) and an MIC -1C and -2C indoor module

MIC-1C AND MIC-2C COLUMN INDOOR MODULE

The MIC allows the entire system to be managed by providing an interface between the outdoor unit and the heating system. It includes all the hydraulic and control components in the front panel to ensure easy installation and operation.

It cannot be installed without the outdoor unit

MAIN DIMENSIONS (MM AND INCHES)

MIC -1C AND 2C

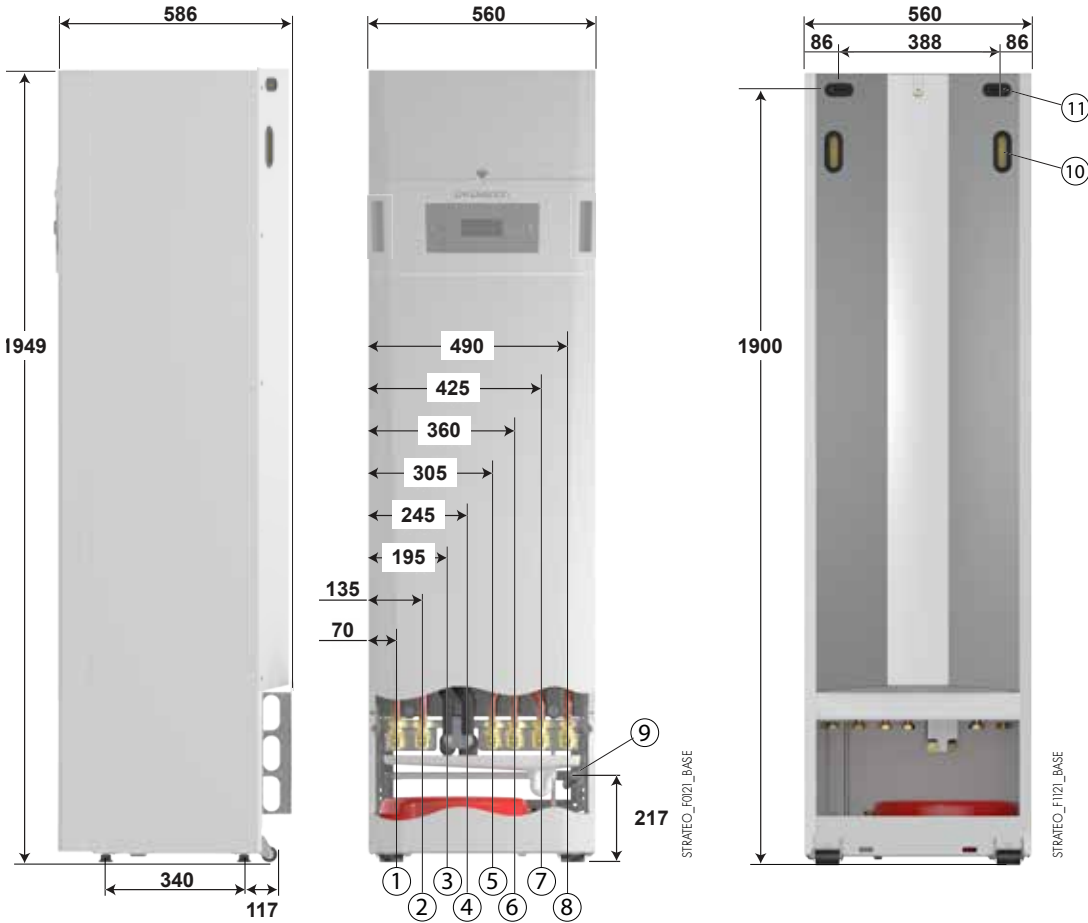

KEY

- ① 2nd circuit return (2C version) G 1"
- ② 2nd circuit flow (2C version) G 1"
- ③ Refrigerant fluid connection, 3/8" flare
- ④ Refrigerant gas connection, 5/8" flare
- ⑤ Domestic hot water outlet Ø R 3/4
- ⑥ Domestic cold water inlet Ø R 3/4
- ⑦ Heating flow Ø G 1"
- ⑧ Heating return Ø G 1"
- ⑨ Outflow Ø 32
- ⑩ Handle
- ⑪ Cable routing

TECHNICAL SPECIFICATIONS

STRATEO

MIC-1C V190 AND MIC-2C V190 INDOOR UNITS

A multifunction hydraulic unit can be accessed from the front panel and contains all the elements required for the operation of the heating system. All the unit components are easy to access. The unit present in the STRATEO ...2C contains the elements required for management of a second circuit with mixing valve.

DETAILS OF THE HYDRAULIC UNIT FOR THE MIC-2C VERSION (WITH FRONT PANEL REMOVED)

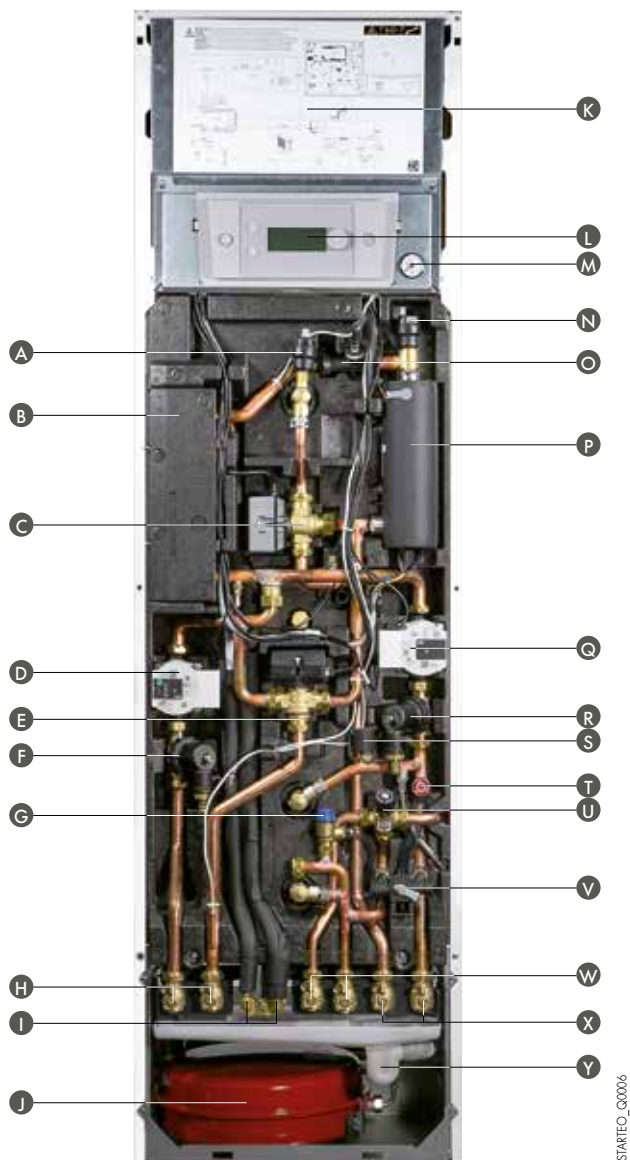

KEY

- A DHW coil drain automatic air vent
- B Plate heat exchanger (condenser)
- C 3-way valve with heating/DHW reversal motor
- D Heating circulating pump for circuit B
- E Circuit B mixing valve
- F Magnetic sludge filter for circuit B
- G 7 bar domestic safety valve
- H Heating circuit B flow/return
- I Refrigerant fluid-gas connection
- J 12-litre expansion vessel
- K Panel containing the electrical boards
- L E-pilot interface
- M Mechanical pressure gauge
- N Heating automatic air vent
- O Flow meter
- P 3 kW electrical back-up
- Q Heating circulating pump for circuit A
- R Magnetic sludge filter for circuit A
- S Electronic pressure gauge
- T 3-bar heating circuit safety valve
- U Thermostatic mixing valve
- V Disconnecter
- W Domestic cold water inlet and hot water outlet
- X Heating circuit A flow/return
- Y Siphon

STRATEO_00006

TECHNICAL SPECIFICATIONS

STRATEO

190-LITRE DHW TANK

The 190-litre DHW tank is located behind the hydraulic kit. The tank is made from enamelled steel (food-grade vitrified enamel with a high quartz content) with a new diameter to enable better stratification. It is equipped as standard with a protective magnesium anode (titanium anode available as an option) and a dielectric union. It is already connected to the hydraulic kit in the front panel.

DETAILS OF THE TANK

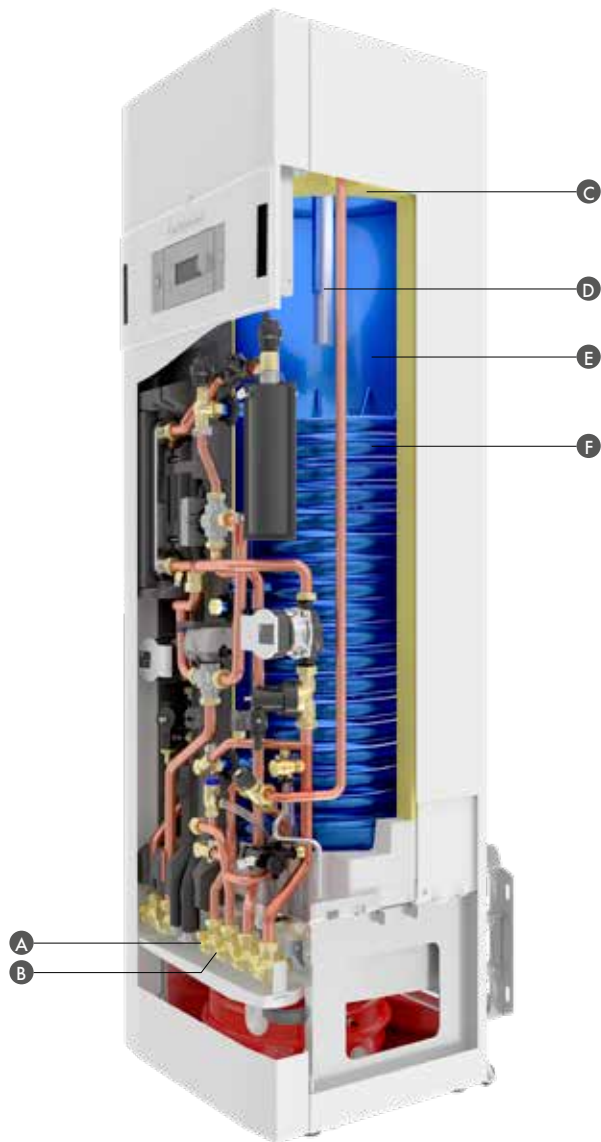

KEY

- A DHW outlet
- B DCW inlet
- C Insulation
- D Magnesium anode or optional titanium anode
- E 190-litre DHW tank
- F Heat exchanger for preparation of DHW (coil)

TECHNICAL SPECIFICATIONS

STRATEO

HYDRAULIC PRE-ASSEMBLY PLATE

The hydraulic preassembly plate must be installed during the work site phase. During the work site phase, this plate is used to connect up all of the hydraulic and cooling circuits before installation of the indoor unit. This plate is equipped with new stop valves with integrated drain valve.

DESCRIPTION OF THE CONNECTION PLATE

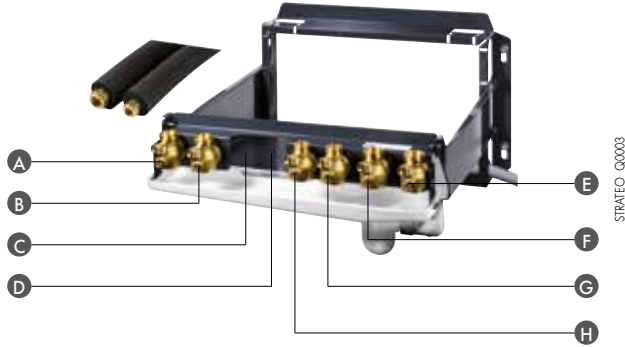

STRATEO_Q0003

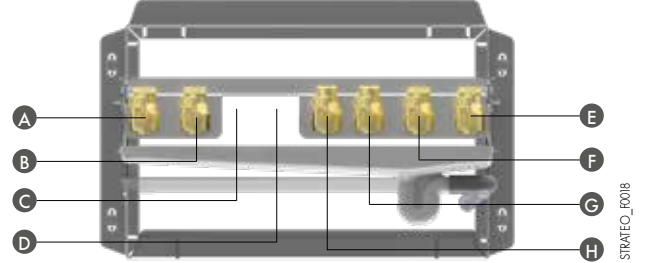

STRATEO_F0018

KEY

A Circuit B return (mixed) Ø 1"
B Circuit B flow (mixed) Ø 1"

C Fluid line opening Ø 3/8"
D Gas line opening Ø 5/8"

E Circuit A return (direct) Ø 1"
F Circuit A flow (direct) Ø 1"

G Domestic cold water inlet Ø 3/4"
H Domestic hot water flow Ø 3/4"

SAFETY VALVE AND CONDENSATE OUTFLOW

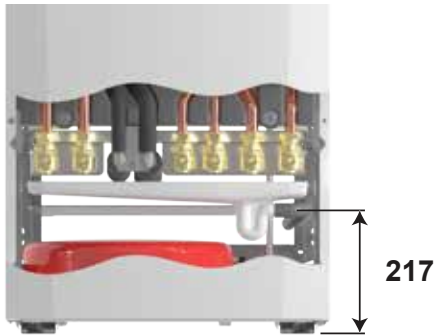

STRATEO_F021_BASE

- The evacuation tube measures approximately 1.50 m.
- **Ensure it runs into a drain at a max height of 200 mm** in relation to the finished floor.
- Angle at a gradient of 1 % to allow the condensate or water evacuated by the safety valves to drain correctly.
- If this gradient cannot be applied, then the lift pump kit (option EH860) must be used.
- The lift pump kit can be used to enable discharge up to a height of 4 m.

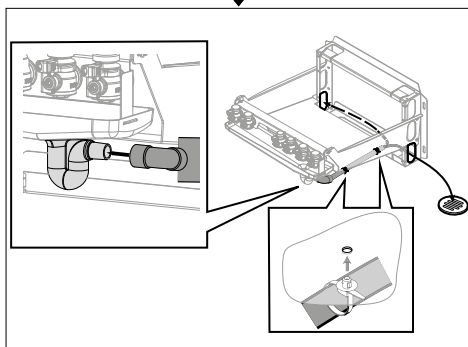
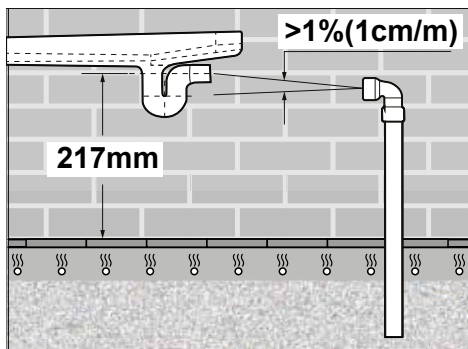

STRATEO_F0017

MULTI-DIRECTIONAL HYDRAULIC CONNECTION PLATE

The patented connection plate has been developed to provide maximum flexibility during installation. It has scored elements and various oblong holes to simplify routing of the tubes.

EXAMPLE OF LEFT OR RIGHT CONNECTION

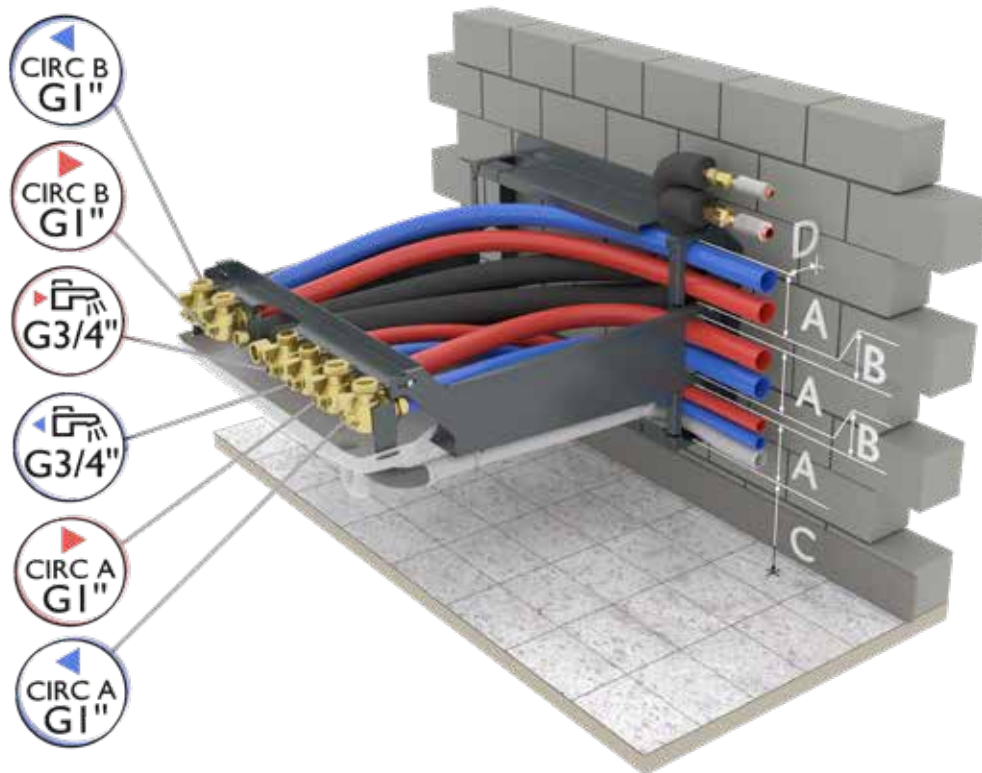

STRATEO_F0200

TUBE ROUTING DIMENSION

A (mm)	B (mm)	c (mm)	D (mm)
90	10	95.5	475



TIPS

- For a right-hand connection (example above), route the DHW tubes with a narrow diameter into the same oblong holes as the condensate evacuation tube.
- For easier routing of the refrigerant tubes, use the 800 mm refrigerant lines supplied with the connection plate.

MULTI-DIRECTIONAL HYDRAULIC CONNECTION PLATE

The patented connection plate has been developed to provide maximum flexibility during installation. It has scored elements and various oblong holes to simplify routing of the tubes. Connection in the crawl space gives the installation an immaculate finish.

EXAMPLE OF CONNECTION INTO THE CRAWL SPACE

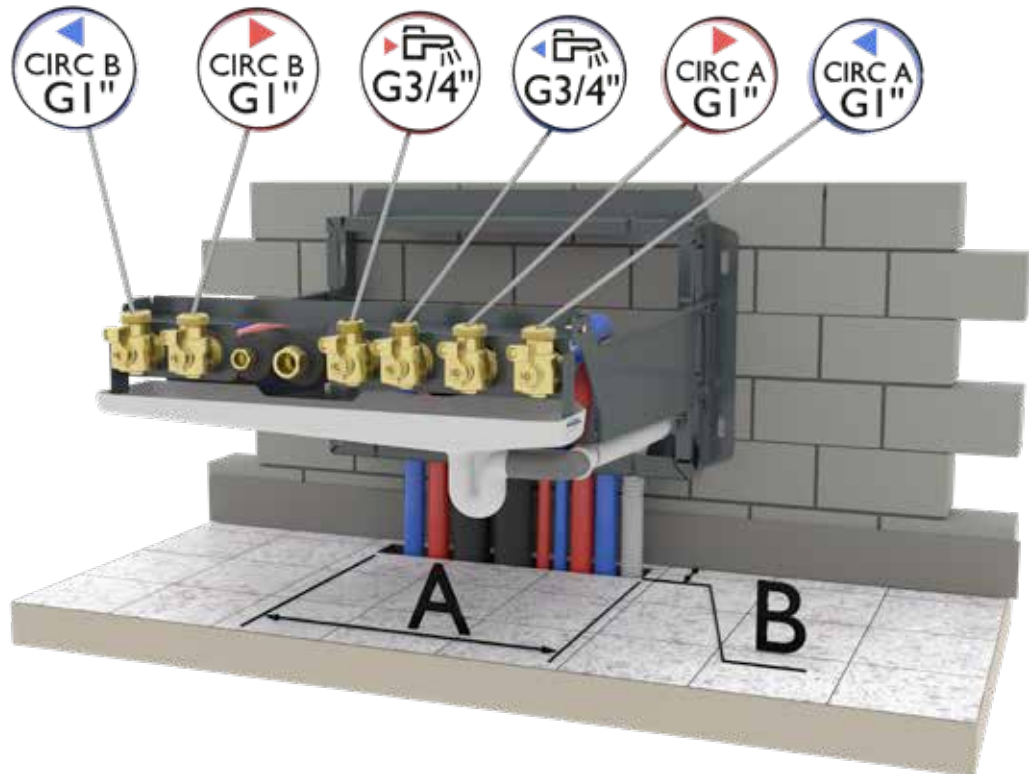

TUBE ROUTING DIMENSION

A (mm)	B (mm)
340	60



TIPS

- Using the EH920 kit (stainless-copper line): bend by hand and connect it all inside the crawl space onto the copper section.
- Using the EH978 kit: 230 mm refrigerant connections pre-flared for connection inside the crawl space.

TECHNICAL SPECIFICATIONS

STRATEO

MULTI-DIRECTIONAL HYDRAULIC CONNECTION PLATE

The patented connection plate has been developed to provide maximum flexibility during installation. It has scored elements and various oblong holes to simplify routing of the tubes. Connection with flush-mounted tubes gives the installation an immaculate finish.

EXAMPLE OF CONNECTION WITH FLUSH-MOUNTED TUBES

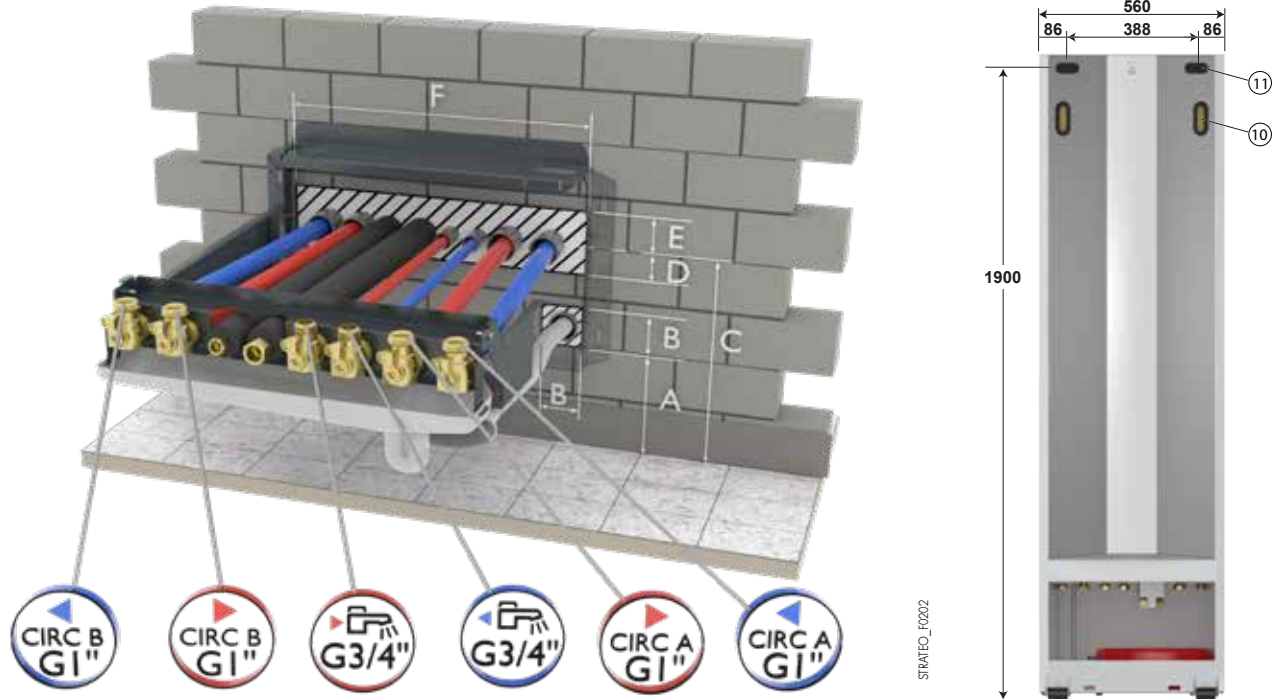

TUBE ROUTING DIMENSION

A (mm)	B (mm)	C (mm)	D (mm)	E (mm)	F (mm)
127	47	279	79	90	435

TIPS

- Also ensure the outlet for the cables and power supplies is 1.90 m from the finished floor. It is located opposite the cable routing opening in the indoor unit.

TECHNICAL SPECIFICATIONS

STRATEO

TECHNICAL SPECIFICATIONS OF AWHP OUTDOOR UNITS

MAIN DIMENSIONS (MM AND INCHES)

AWHP 4.5 MR

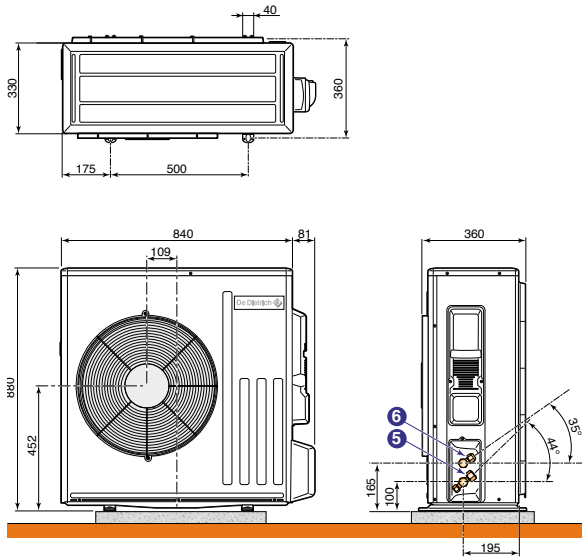

PAC_F0304

AWHP 6 MR-3

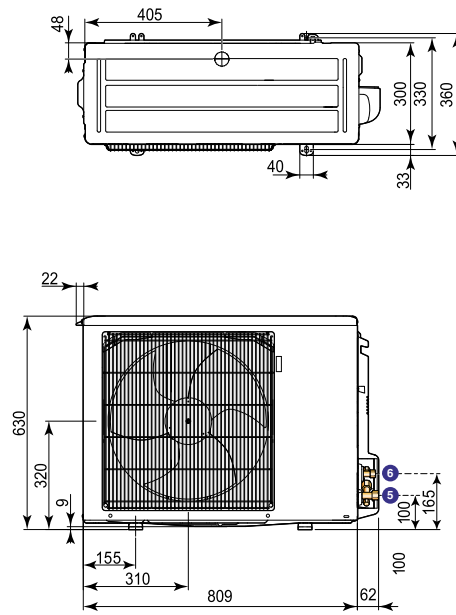

PAC_F0226

AWHP 8 MR-2

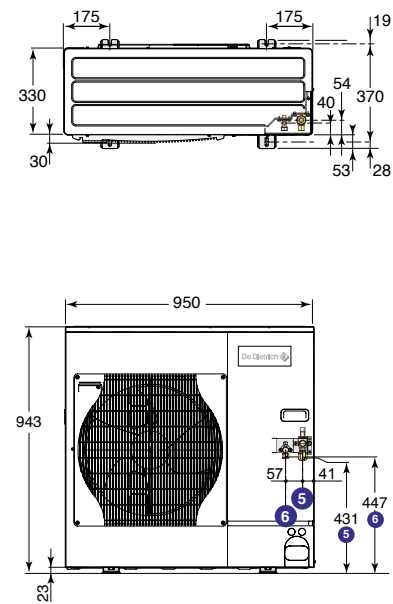

PAC_F0087C

KEY

- ⑤ Refrigerant gas connection:
 - AWHP 4.5 and 6...: 1/2" flare (1/2" - 5/8" connection supplied)
 - AWHP 8: 5/8" flare
 - MIC...: 5/8" flare
- ⑥ Refrigerant fluid connection:
 - AWHP 4.5 and 6...: 1/4" flare (1/4" - 3/8" connection supplied)
 - AWHP 8: 3/8" flare
 - MIC...: 3/8" flare

TECHNICAL SPECIFICATIONS

STRATEO

TECHNICAL SPECIFICATIONS OF OUTDOOR UNITS

COMPONENTS

AWHP 4.5 MR

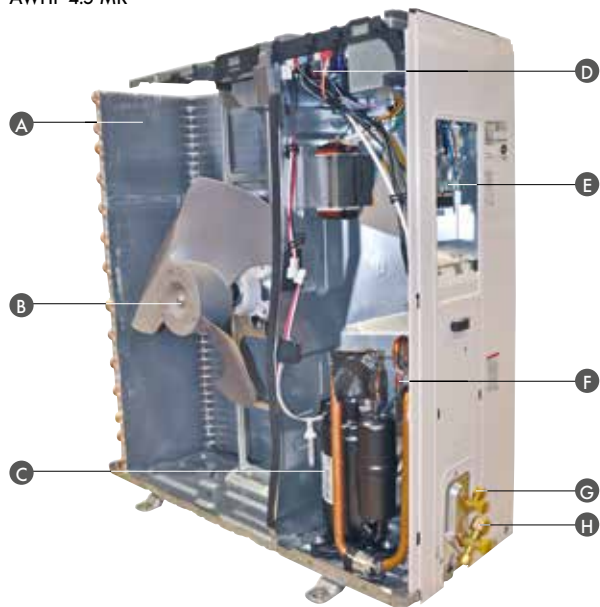

PAC_Q0525

- A Evaporator
- B Fan
- C Compressor
- D Electronic circuit board

- E Electrical connection
- F Cycle reversal 4-way valve
- G Refrigerant fluid connection
- H Refrigerant gas connection

AWHP 6 MR-3



PAC_Q0121

- A Evaporator
- B Fan
- C Electronic circuit board
- D "Inverter" compressor with power accumulator

- E Refrigerant fluid connection (not shown)
- F Refrigerant gas connection (not shown)

AWHP 8 MR-2



PAC_Q0525

- A Evaporator
- B Fan
- C Electronic circuit board
- D Cycle reversal 4-way valve

- E Refrigerant gas connection
- F Refrigerant fluid connection
- G "Inverter" compressor with power accumulator

CONTROL PANEL

CONTROL PANEL ON THE MIC-1C/2C

The control panel on the MIC module of STRATEO heat pumps include an electronic control system that allows the heating output to be adapted to the real system requirements based on the outdoor temperature (sensor supplied). To do this, the control system manages the compressor modulation (via the BUS cable connecting the outdoor unit to the MIC) and, if necessary, the back-up by the immersion heater.

With the MIC-1C, it enables management of a single direct circuit, which may be a radiator circuit or one low temperature underfloor heating circuit (or even convection fans). With the MIC-2C, it enables management of 2 heating circuits (direct and with mixing valve for underfloor heating or radiator). In addition, this control system manages the automatic reversibility between heating in winter and cooling-air conditioning in summer. The control system also allows the domestic hot water to be managed.



DESCRIPTION OF THE SCREENS

STANDBY SCREEN

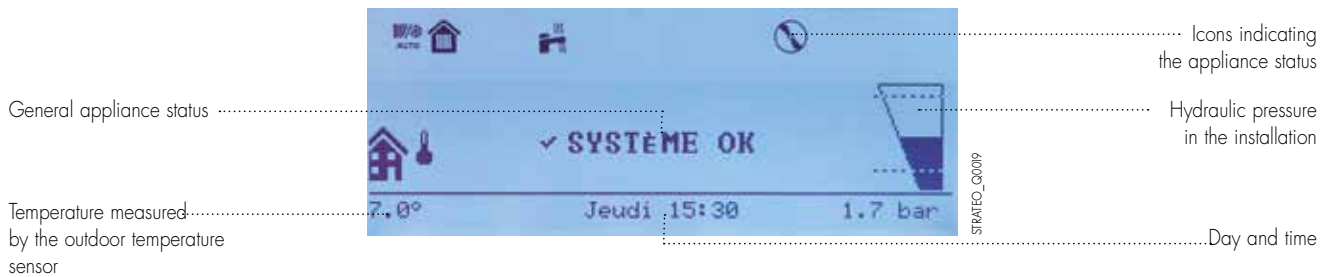

HOME SCREEN

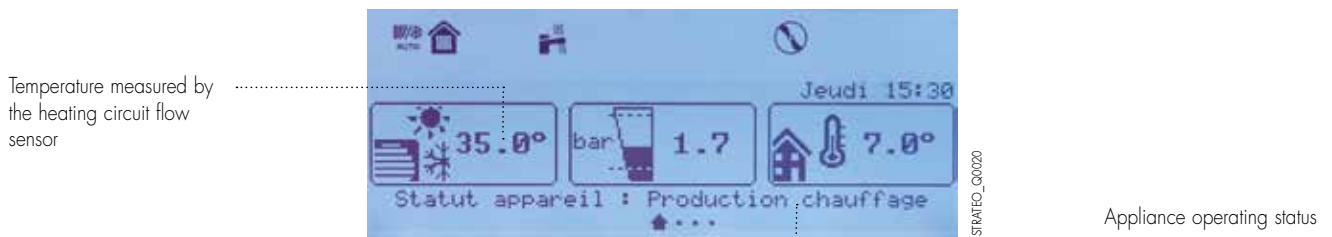

ZONE DESCRIPTION SCREEN



HEAT PUMP OPTIONS

STRATEO

CONTROL PANEL OPTIONS

AD140



AD200



8666Q P20A - 8801 Q003

WIRED PROGRAMMABLE ROOM THERMOSTAT - PACKAGE AD137

WIRELESS PROGRAMMABLE ROOM THERMOSTAT - PACKAGE AD200

NON-PROGRAMMABLE ROOM THERMOSTAT - PACKAGE AD140

Programmable thermostats provide weekly programming and regulation of the heating according to the various operating modes: "Automatic" based on the programming, "Permanent" at a set temperature or "Holiday". The "wireless" version is delivered with a receiver box to be mounted on the wall.

The non-programmable thermostat is only used to regulate the room temperature based on the setpoint.



HA249_Q001

CONNECTION KIT FOR DIRECT UNDERFLOOR HEATING - PACKAGE HA249

This wiring harness is inserted into the heating pump, and contains the wires for connecting the safety thermostat for underfloor heating.



SMARTTC_Q007

SMART TC° CONNECTED ROOM THERMOSTAT (WIRED R-BUS) - PACKAGE AD324

Equipped with a backlit colour screen and a dedicated dropdown menu to simplify use, this is used to control the heating and domestic hot water remotely via an application which can be downloaded free of charge. This application is easy for the user to navigate, and includes the option to provide a professional with access to their installation (via authorisation). This smart thermostat enables precise remote control of temperatures and modulation, incorporates various timer programs with programming help, and provides access to the installation's parameters, including tracking of consumption, with data backup.

Smart TC° can also operate as a conventional remote control without WiFi, or application. However, it is still recommended to connect it to the internet to benefit from the latest updates.

For further details, see the dedicated technical leaflet.

installation principle

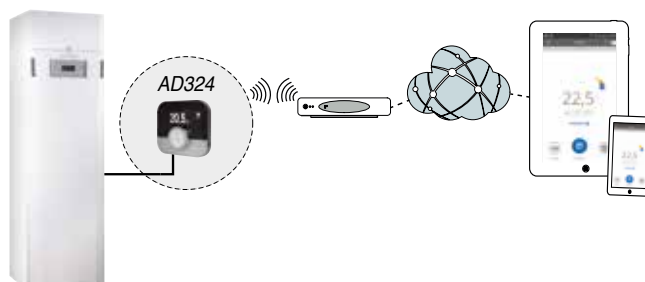

STRATEO_F1000



HF1_Q0017

HUMIDITY - COOLING SENSOR (ON/OFF) - PACKAGE HK27

Sensor measuring the humidity rate. It must be installed on the flow for the underfloor heating/cooling. In "cooling" mode, it enables the heat pump to be switched off when the humidity rate becomes too high to prevent the formation of condensation.



HYBRID_Q0050

CONDENSATION SENSOR KIT (0 - 10 V) - PACKAGE HZ64

Sensor measuring the humidity rate. It must be installed on the flow for the underfloor heating/cooling. In "cooling" mode, it enables the flow water temperature to be adapted to prevent the formation of condensation.



STRATEO_Q0015

ACTIVE ANODE KIT (TAS) - EH921

Active titanium anode protecting the domestic hot water tank, designed to replace the factory-fitted magnesium anode



HYBRID_Q0011

OUTDOOR MODULE SILENT RUNNING KIT (EXCEPT AWHP 4.5MR) - PACKAGE EH572

After installation, this enables the level of noise produced by the outdoor unit to be reduced.



STRATEO_Q0002

2ND CIRCUIT PCB KIT - EH916

PCB for controlling the 2nd mixed circuit. It must be installed to manage the second mixed circuit. Only required to convert the MIC 1C V190 into the MIC 2C V190 version.

Important: the EH916 kit is to be used in conjunction with EH917 kit.

HEAT PUMP OPTIONS

STRATEO

OPTIONS FOR THE OUTDOOR UNIT



AWHP 4.5 MR, 6 MR-3 AND 8 MR-2 WALL MOUNTING SUPPORT... + ANTI-VIBRATION MOUNTS - PACKAGE EH95

This kit enables the outdoor unit for the AWHPs to be fixed to the wall. It is equipped with anti-vibration mounts which reduce the transmission of vibrations to the ground.



AWHP GROUND MOUNTING SUPPORT - PACKAGE EH112

Tough, durable PVC support for mounting the outdoor unit on the ground. Bolts, washers and nuts are included for quick, easy installation.



RUBBER FLOOR SUPPORT - PACKAGE EH879

Durable rubber support for mounting the outdoor unit on the ground.



REFRIGERATION CONNECTION KIT 5/8" - 3/8": - LENGTH 5 M - PACKAGE EH114 - LENGTH 10 M - PACKAGE EH115 - LENGTH 20 M - PACKAGE EH116

REFRIGERATION CONNECTION KIT 1/2" - 1/4": - LENGTH 10 - PACKAGE EH142

High-quality insulated copper pipe limiting heat loss and condensation.



FLEXIBLE REFRIGERANT CONNECTIONS 5/8" 3/8" - LG 2.3 M - EH978

Insulated flexible refrigerant lines 2.30 m in length, to connect the indoor unit to the outdoor unit.

OPTIONS FOR THE INDOOR UNIT



BUFFER TANK: - B 80 T - PACKAGE EH 85 - B 150 T - PACKAGE EH60

These 80 and 150 litre tanks are used to limit compressor short cycle operation and to provide a reserve for the defrosting phase on reversible air-to-water heat pumps.

It is also recommended for all heat pumps connected to installations with a water volume of less than 5 l/kW of heat output.

EXAMPLE: Heat pump output = 10 kW
Min. volume in the installation: 50 litres
Dimensions: B 80 T: H 850 x L 440 x D 450 mm
B 150 T: H 1003 x Ø 601 mm

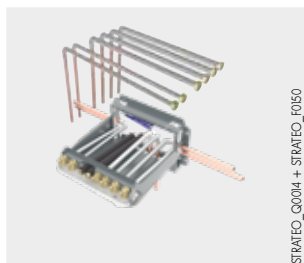

6 HYDRAULIC TUBES FOR CONNECTION TO COPPER PIPE - EH920

Mandatory for copper connections to guarantee height adjustment when connecting the plate to the product.

Allows the plate to be removed and **simplifies** crimping or brazing of the copper

CAUTION: protect stainless steel copper welds with heat absorbing paste (or a damp cloth)



LIFT PUMP KIT - EH860

Required if outflow into the drain exceeds 20 cm

The lift pump is integrated inside the indoor unit next to the expansion vessel



2ND CIRCUIT HYDRAULIC KIT - EH917

Hydraulic assembly enabling management of a 2nd circuit. This kit includes a high-efficiency circulating pump, a mixing valve, 2 stopcocks, a magnetic filter and a flow sensor

It must be installed to manage the second mixed circuit. Only required to convert the MIC 1C V190 into the MIC 2C V190 version.

Important: the EH917 kit is to be used in conjunction with EH916 kit

SIZING AN INSTALLATION

STRATEO

SIZING AIR-TO-WATER HEAT PUMPS

The heat pump is sized on the basis of the heat loss calculation. The heat losses are calculated in accordance with standard NF EN 12831 and the national supplement NF P 52-612/CN. The losses are calculated for rooms heated by the heat pump, and are divided into:

- surface losses through walls,
- linear losses where the different surfaces are joined,
- losses through air renewal and infiltration.

Air-to-water heat pumps alone cannot compensate for losses in a building, since their output decreases as the outdoor temperature drops, and they even shut down at a temperature known as the "shutdown temperature". This temperature is -20 °C for our STRATEO range (-15 °C 4.5 and 6 kW). An electrical back-up is then required. The balance temperature corresponds to the outdoor temperature at which the heat pump's output is equal to the losses.

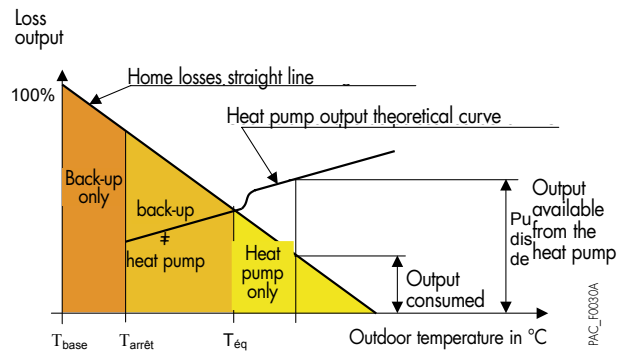

! FOR OPTIMAL SIZING, IT IS RECOMMENDED TO FOLLOW THE RULES BELOW

- 70 % of losses Heat pump output at T_o 100 % of losses where $T_o = T_{base}$ if $T_{shutdown} < T_{base}$ and $T_o = shutdown$ if it does not (take a value of 80% if the building inertia is low, for example wooden framework)
- Heat pump output at T_{base} + Back-up output = 120 % of losses

T_{base} = Base outdoor temperature,
 T_{bal} = Balance temperature,
 $T_{shutdown}$ = Shutdown temperature (see tables on page 5).

By applying these sizing rules, coverage rates of around 80 % to 90 % or more can be achieved, depending on the case. For more detailed calculations, you can use our DiemaPAC calculation tool in the Pro area of our website:

www.dedietrich-thermique.fr

SELECTION TABLES FOR STRATEO MODELS

These tables provided a simplified definition of the PAC output to be installed.

We strongly recommend the our sizing tool is used for selecting the heat pump.

(PRO access): http://pro.dedietrich-thermique.fr/fr/site_pro/logiciels/diemasoft/diema_tools_la_boite_a_ouils

• STRATEO FOR A FLOW AT 35 °C (UNDERFLOOR HEATING)

LOSSES IN KW	3	4	5	6	7	8	9
0							
-1							
-2							
-3							
-4							
-5							
-6							
-7	4.5 MR+3	4.5 MR+3	4.5 MR+3	6 MR+ 3	6 MR+ 3	8MR+3	8 MR + 3
-8	4.5 MR+3	4.5 MR+3	4.5 MR+3	6 MR+ 3	6 MR+ 3	8MR+3	8 MR + 3
-9	4.5 MR+3	4.5 MR+3	4.5 MR+3	6 MR+ 3	6 MR+ 3	8MR+3	8 MR + 3
-10	4.5 MR+3	4.5 MR+3	4.5 MR+3	6 MR+ 3	6 MR+ 3	8MR+3	8 MR + 3
-11	4.5 MR+3	4.5 MR+3	4.5 MR+3	6 MR+ 3	6 MR+ 3	8MR+3	8 MR + 3
-12	4.5 MR+3	4.5 MR+3	4.5 MR+3	6 MR+ 3	6 MR+ 3	8MR+3	8 MR + 3
-13	4.5 MR+3	4.5 MR+3	4.5 MR+3	6 MR+ 3	6 MR+ 3	8MR+3	8 MR + 3
-14	4.5 MR+3	4.5 MR+3	4.5 MR+3	6 MR+ 3	6 MR+ 3	8MR+3	8 MR + 3
-15	4.5 MR+3	4.5 MR+3	4.5 MR+3	6 MR+ 3	6 MR+ 3	8MR+3	8 MR + 3
-16	8MR+3	8MR+3	8MR+3	8MR+3	8MR+3	8MR+3	8MR+3
-17	8MR+3	8MR+3	8MR+3	8MR+3	8MR+3	8MR+3	8MR+3
-18	8MR+3	8MR+3	8MR+3	8MR+3	8MR+3	8MR+3	8MR+3
-19	8MR+3	8MR+3	8MR+3	8MR+3	8MR+3	8MR+3	8MR+3
-20	8MR+3	8MR+3	8MR+3	8MR+3	8MR+3	8MR+3	8MR+3

SIZING AN INSTALLATION

STRATEO

• STRATEO FOR A FLOW AT 45 °C (LOW TEMPERATURE RADIATOR)

LOSSES IN KW	3	4	5	6	7	8	9	
0	4.5 MR+3	4.5 MR+3	4.5 MR+3	6 MR+3	8MR+3	8MR+3	8 MR +3	
-1								
-2								
-3								
-4			8MR+3	8MR+3	6 MR+3	8MR+3	8MR+3	8MR+3
-5								
-6								
-7								
-8	8MR+3	8MR+3	6 MR+3	8MR+3	8MR+3	8MR+3		
-9								
-10								
-11								
-12	8MR+3	8MR+3	8MR+3	8MR+3	8MR+3	8MR+3		
-13								
-14								
-15								
-16	8MR+3	8MR+3	8MR+3	8MR+3	8MR+3	8MR+3		
-17								
-18								
-19								
-20	8MR+3	8MR+3	8MR+3	8MR+3	8MR+3	8MR+3		
-1								
-2								
-3								

• STRATEO FOR A FLOW AT 55 °C (MID TEMPERATURE RADIATOR)

LOSSES IN KW	3	4	5	6	7	8	9
0	4.5 MR+3	4.5 MR+3	4.5 MR+3	6 MR+3	8MR+3	8MR+3	8MR+3
-1							
-2							
-3							
-4	6 MR+3	6 MR+3	6 MR+3	8MR+3	8MR+3	8MR+3	
-5							
-6							
-7							
-8	6 MR+3	6 MR+3	6 MR+3	8MR+3	8MR+3	8MR+3	
-9							
-10							
-11							

shaded boxes: not included in DTU65.16 recommendations. Consult us

NOTES

- Data selection tables for each flow temperature according to the sizing rules stated in DTU65.16 (170% of losses for the heat pump and 120% of losses for the heat pump + back-up)
- The losses must be calculated accurately and without a surplus power coefficient.
- + 3 corresponds to the minimum electrical back-up required in kW
- **Below the heat pump's outdoor shutdown temperature (- 20 °C or - 15 °C for 4.5 and 6 kW models), only the back-ups operate.**
- For sizing in cooling mode, refer to page 5 for the flows in air conditioning mode at 7 °C or in cooling mode at 18 °C. We recommend using the AWHP table available on the site.

IMPORTANT INFORMATION FOR INSTALLATION

INDOOR UNIT: POSITIONING RULES

The STRATEO indoor unit should be installed in a frost-free location on a flat surface as close as possible to draw-off points to limit losses. Access must be possible at the front to facilitate maintenance of the appliance.

The indoor unit may be mounted in a cabinet or against a wall.

The indoor unit is equipped with wheels at the rear of the product to facilitate its positioning.

MOUNTING IN A CABINET



MOUNTING AGAINST A WALL

Respect the routing of the tubes on the connection plate. No tube must be routed horizontally on top of the plate as the back of the product will be placed against a wall, or underneath as the wheels enabling the product to be positioned will also be against the skirting board.

On the indoor unit upper panel, a bracket can be unfolded and secured to the wall to prevent any risk of the product tipping over once installed.

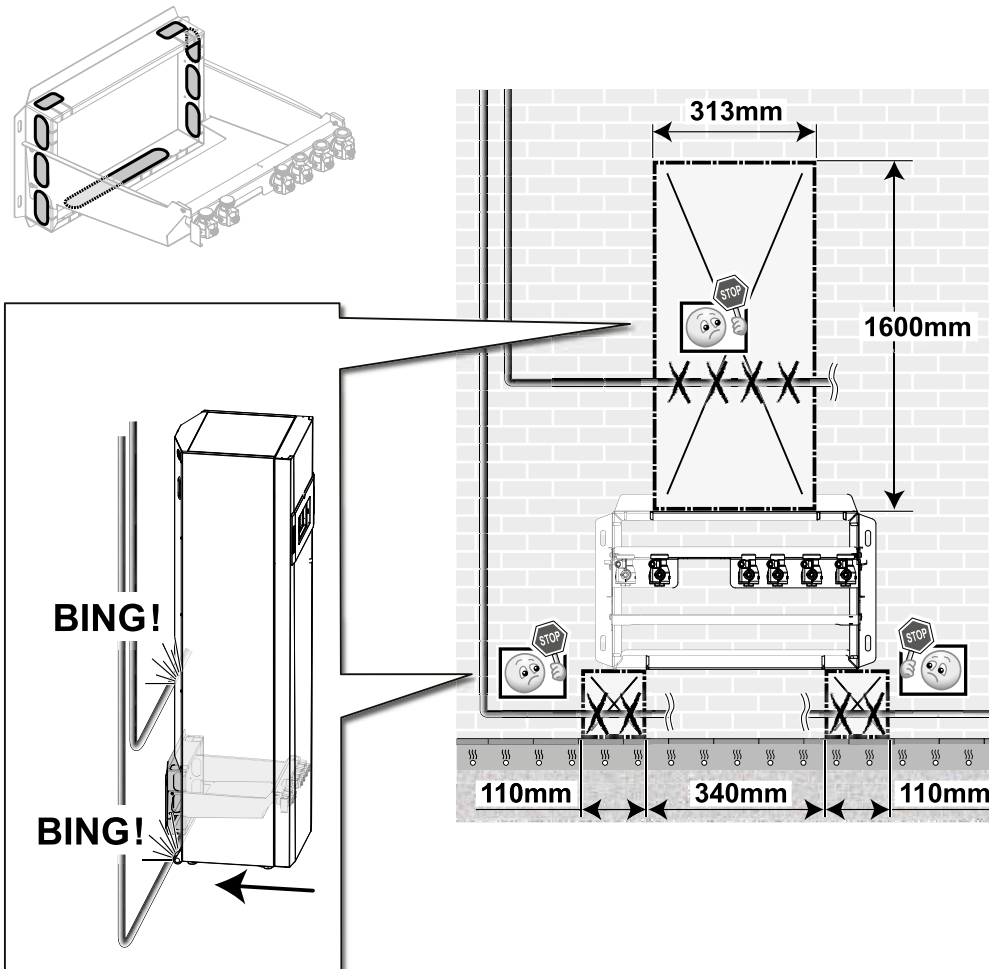

STRATEO_F0151

IMPORTANT INFORMATION FOR INSTALLATION

POSITIONING STRATEO HEAT PUMPS

- The outdoor units on STRATEO heat pumps are installed near the home, on a terrace or façade or in a garden. They are designed to operate in rainy conditions but can also be installed in a sheltered location with ventilation.
- The outdoor unit must be installed in a location sheltered from prevailing winds, which can affect the performance of the installation.
- The unit should be positioned above the annual snowfall height in the region in which it is installed.
- The location for the outdoor unit should be chosen carefully to meet the environmental requirements: integration in the site, compliance with urban planning and co-ownership rules.
- There should be nothing obstructing the free circulation of air over the heat exchanger at the inlet and outlet; a space should therefore be left around the appliance. This will enable connection, commissioning and maintenance operations to be carried out (see layout plans below).

OUTDOOR UNIT: MINIMUM POSITIONING DISTANCES (MM)

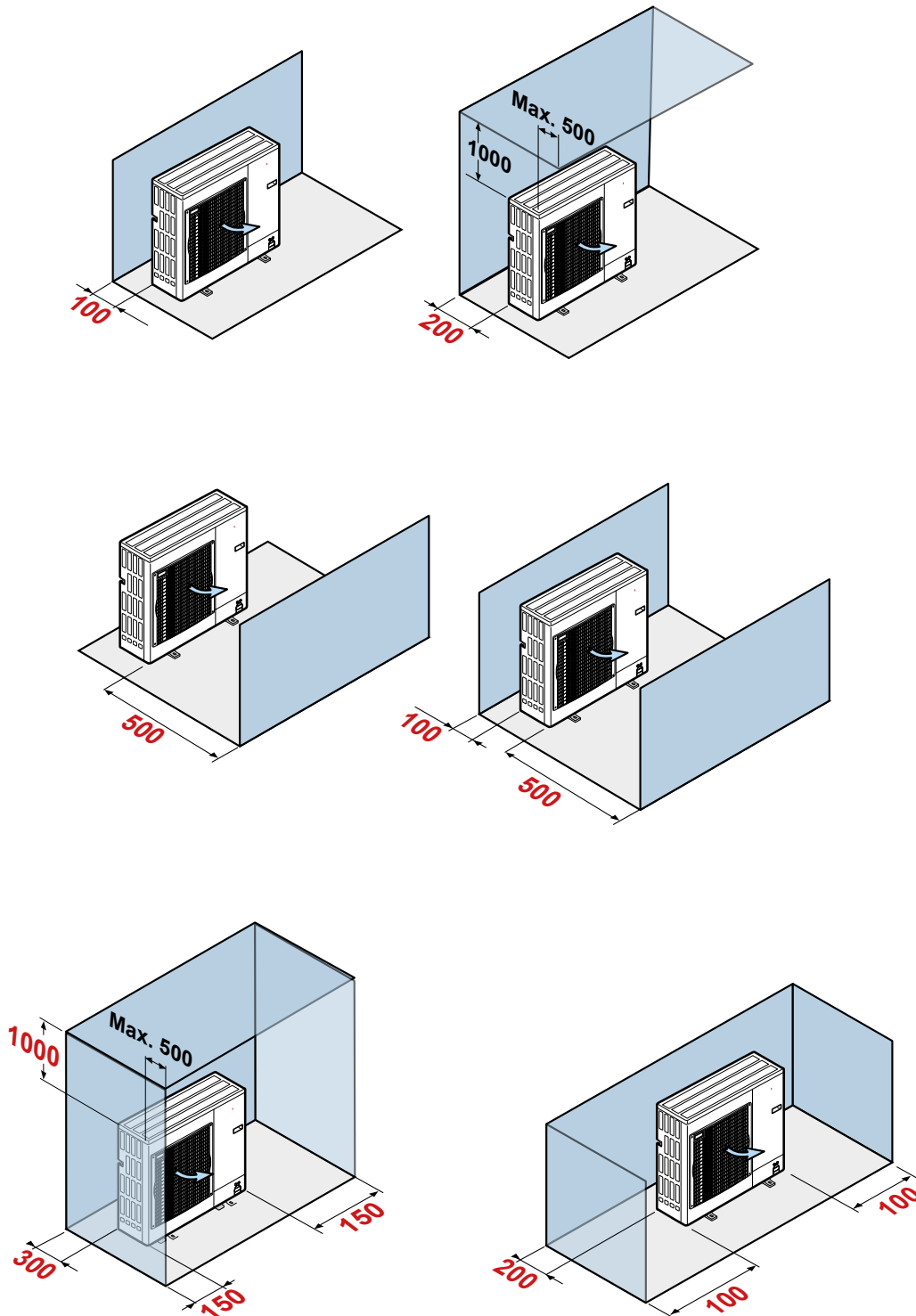

IMPORTANT INFORMATION FOR INSTALLATION

MAXIMUM DISTANCES AND REFRIGERANT FLUID LOAD QUANTITY

MAXIMUM CONNECTION DISTANCES (SEE DIAGRAM BELOW)

STRATEO	4.5 MR/E	6 MR/E	8 MR/E
refrigerant gas connection Ø	1/2"	1/2"	5/8"
refrigerant liquid connection Ø	1/4"	1/4"	3/8"
L (m)	2 - 30	2 - 40	2 - 40
B (m)	30	30	30

L: minimum and maximum connection distance between the indoor module and the outdoor unit.
B: maximum permitted height difference between the indoor module and the outdoor unit.

REFRIGERANT PRELOAD QUANTITY

No additional refrigerant fluid load is required if the refrigerant pipe is less than 10 m long. For lengths above 10 m, the following additional loads are required:

MODELS	ADDITIONAL REFRIGERANT FLUID LOAD (KG) FOR A PIPE LENGTH > 10 M					
	11 TO 20 m	21 TO 30 m	31 TO 40 m	41 TO 50 m	51 TO 60 m	61 TO 75 m
STRATEO 6 MR/E	0.2	0.4	0.6	—	—	—
STRATEO 8 MR/E	0.15	0.3	0.9	—	—	—

MODELS	ADDITIONAL REFRIGERANT FLUID LOAD (KG) FOR A PIPE LENGTH > 7 M					
	7 m	10 m	15 m	20 m	30 m	YG/m
STRATEO 4.5 MR/E	0	0.045	0.120	0.195	0.345	15 (l)

(l) Calculation: $X_g = Y_g/m$ (pipe length (m) - 7)

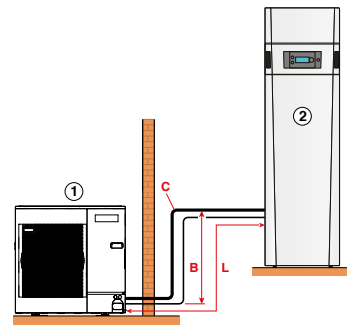

B: max. height difference
L: maximum connection distance
C: 15 elbows max. (except 4.5 MR...:10)
① Outdoor unit
② Indoor module

STRATEO_F2000

ACOUSTIC INTEGRATION OF STRATEO HEAT PUMPS

DEFINITIONS

The acoustic performance levels of the outdoor units are defined by the following two values:

- **The sound power L_w expressed in dB(A)**: it characterises the sound emission capacity of the source, independently of its environment. It allows the appliances to be compared.
- **The acoustic pressure L_p expressed in dB(A)**: this is the value perceived by the human ear, and depends on parameters including the distance from the source and the size and type of walls in the room. The regulations are based on this value.

NOISE NUISANCE

Regulations concerning neighbourhood noise can be found in the decree of 31/08/2006 and in standard NF S 31-010. Noise nuisance is defined by the emergence, which is the difference between the sound pressure level measured when the appliance is switched off and the level measured when the appliance is operating in the same location.

The maximum authorised difference is: - day (7 am - 10 pm): 5 dB (A)
- night (10 pm - 7 am): 3 dB (A).

RECOMMENDATIONS FOR ACOUSTIC INTEGRATION OF THE OUTDOOR MODULE

- Do not place it close to where people sleep,
- Avoid placing it close to a terrace, and do not install the module opposite a wall. The increase in the noise level due to the installation configuration is shown in the diagrams below:

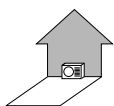

Module positioned against a wall: + 3 dB(A)

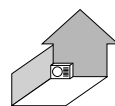

Module positioned in a corner: + 6 dB(A)

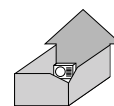

Module positioned in an inner courtyard: + 9 dB(A)

- The layouts shown below are forbidden:



Ventilation directed towards the neighbouring property



Module at the property boundary



Module positioned under a window

- To limit noise nuisance and the transmission of vibrations, we recommend:
 - installing the outdoor module on a metal frame or an inertia base. This base must weigh at least twice as much as the module, and it must be separate from the building. In all cases, anti-vibration mounts must be installed to reduce the transmission of vibrations.
 - The use of suitable sleeves for routing refrigerant connections through walls,
 - The use of flexible, anti-vibration materials for mountings,
 - The installation of vibration damping devices such as loops, bends or elbows on refrigerant connections.
 - It is also recommended to install an acoustic attenuation device, for example:
 - sound-absorbent wall material to be installed on the wall behind the module,
 - a sound barrier: the surface of the barrier must be larger than the outdoor module and positioned as close as possible to it, while allowing air to circulate freely. The barrier must be made from a suitable material such as acoustic bricks, concrete blocks covered with absorbent material. It is also possible to use natural barriers, such as banks of earth.

HPI_F0029

HPI_F0029

IMPORTANT INFORMATION FOR INSTALLATION

REFRIGERANT CONNECTION

Commissioning STRATEO heat pumps involves operations on the refrigerant circuit.

The appliances must be installed, commissioned, maintained and repaired by qualified, authorised personnel in accordance with the requirements of directives, laws, applicable regulations and good industry practice. See also the "General information" leaflet.

MULTI-DIRECTIONAL REFRIGERANT CONNECTION

All of the flexible refrigerant lines offer highly modular installation options to greatly simplify connection.

- Left or right connection with flexible refrigerant lines factory-supplied with the connection plate
- vertical connection at the top rear of the indoor unit using the EH978 kit78

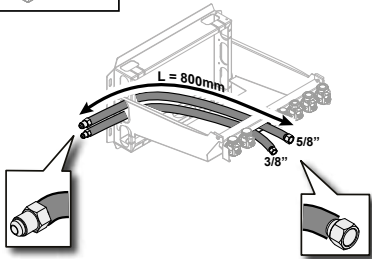
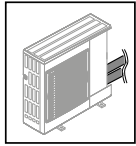

STRATEO_I0018

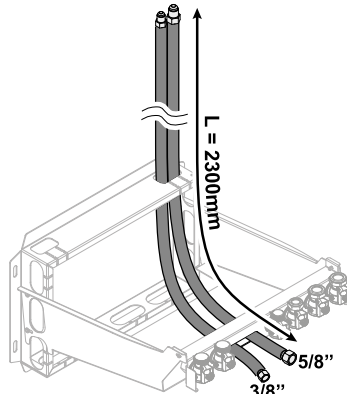

STRATEO_I0013

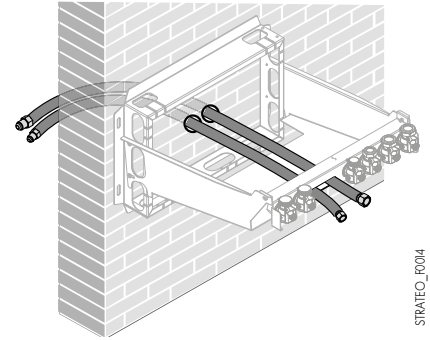

STRATEO_I0014

ELECTRICAL CONNECTION

The heat pumps must be electrically installed in accordance with good industry practice, applicable standards, decrees and associated texts, in particular standard NF C 15 100.

RECOMMENDATION ON CIRCUIT BREAKERS AND CABLE CROSS SECTIONS TO BE USED

STRATEO HEAT PUMP	TYPE	OUTDOOR UNIT					INDOOR UNIT		
		NOMINAL AMPERAGE + 7/35 °C	START-UP AMPERAGE + 7/35 °C	MAXIMUM AMPERAGE	OUTDOOR UNIT POWER SUPPLY		MIV-3 INDOOR MODULE POWER SUPPLY		COMMUNICATION BUS
					CS (mm ²)	CURVE C* CB	CS (mm ²)	CURVE C CB	CS (mm ²)
4.5 MR/E	Single	4.25	5	12	3 x 2.5	16 A	3 x 1.5	10 A	2 x 0.75
6 MR/E	Single	6.57	5	13	3 x 2.5	16 A	3 x 1.5	10 A	2 x 0.75
8 MR/E	Single	8.99	5	17	3 x 4	25 A	3 x 1.5	10 A	2 x 0.75

ELECTRICAL BACK-UP

SINGLE-PHASE: 3 kW	CS	3 x 2.5 mm ²
	CB	Curve C, 16 A

KEY

CS = cable cross section in mm²

CB = circuit breaker

* differential protection motor

ROUTING LOW VOLTAGE AND VERY LOW VOLTAGE CABLES

The product's power supply cables and the power supply cable for the electrical back-ups (on the left) have been separated from the communication cables and the sensors (on the right). It is recommended that shielded cables are used to prevent any disruption of the low voltage network.

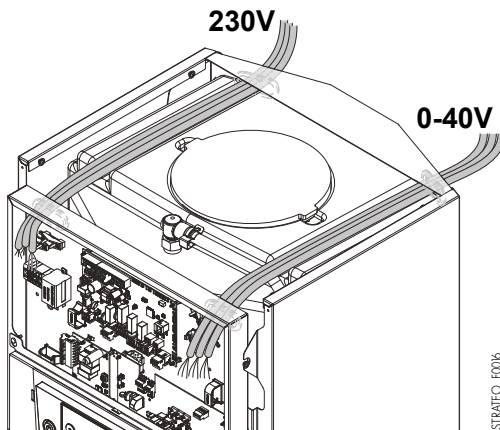

STRATEO_I0016

IMPORTANT INFORMATION FOR INSTALLATION

CONNECTION DIAGRAM WITH DELTADORE ENERGY METER

Connection diagram between the STRATEO and the EMIC DeltaDore unit

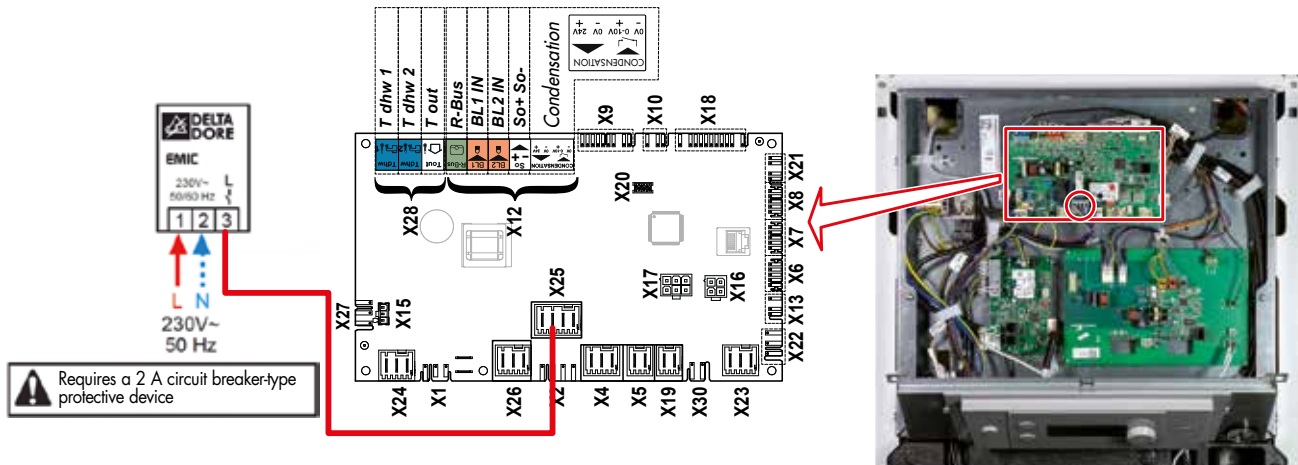

HYDRAULIC CONNECTION

The MIC indoor module on the STRATEO...1C model is fully equipped for the connection of a direct circuit (radiators or underfloor heating). The STRATEO ...2C model enables connection of an additional circuit with mixing valve.

NOTE

STRATEO heat pumps are "SPLIT INVERTER" type appliances with a refrigerant connection between the outdoor unit and the MIC module; it is not necessary to add glycol to the installation.

TOTAL DYNAMIC HEAD OF THE DIRECT HEATING CIRCUIT (CIRCUIT A)

· at the outlet of the STRATEO indoor unit
with WILO PARA 15/8-75/PWM heating circulating pump

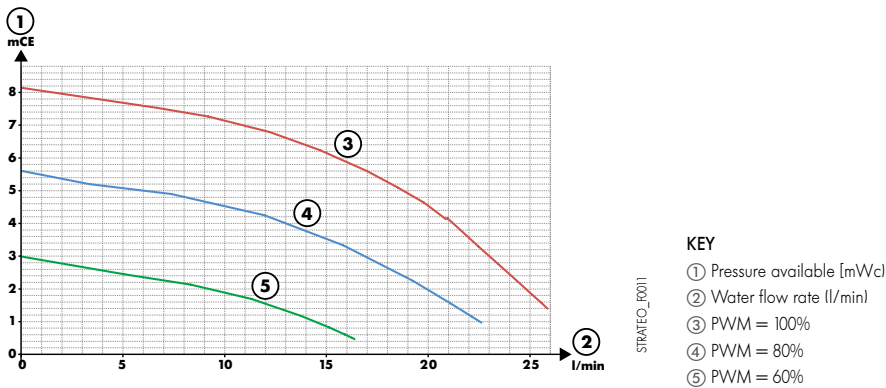

TOTAL DYNAMIC HEAD OF THE MIXED HEATING CIRCUIT (CIRCUIT B)

· at the outlet of the STRATEO indoor unit
with WILO PARA 15/8-75/SC mixed heating circulating pump

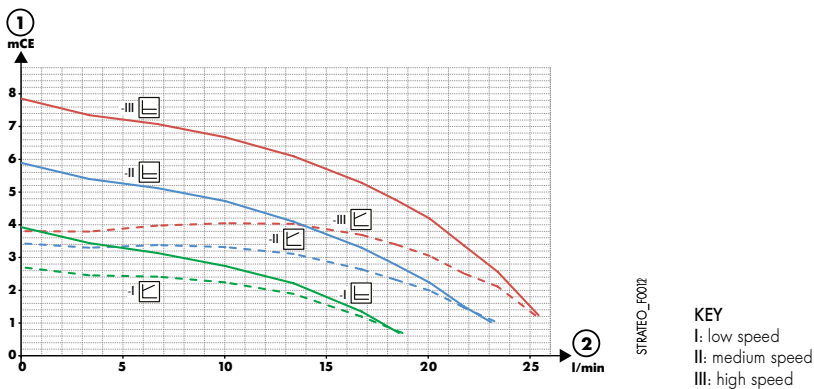

IMPORTANT INFORMATION FOR INSTALLATION

IMPORTANT NOTES

The different emitters

Heat pumps have a limited water outlet temperature: max. 60 °C. It is therefore essential to work on low temperature emitters, for example underfloor heating/cooling or radiators sized for low temperatures. In cooling mode, only underfloor heating with compatible screed and covering is suitable. It is also necessary to comply with the minimum under floor cooling flow temperatures for the geographical installation area to avoid condensation phenomena (between 18°C and 22°C).

refrigerant fluids

R410A refrigerant fluid has properties suited to heat pumps. It belongs to the HFC (Hydrofluorcarbon) family comprising chemical molecules containing carbon, fluorine and hydrogen. They do not contain chlorine, and are therefore not harmful to the ozone layer.

cooling or air conditioning mode

These 'reversible' heat pumps can be used for cooling in the summer. A 4-way valve known as a cycle reversal valve switches the cycle from heating to cooling mode automatically.

The compressor suction is connected to the internal exchanger, which becomes an evaporator. The compressor discharge is connected to the external exchanger, which then becomes a condenser.

NOTE: For air-to-water type heat pumps, this 4-way valve is also used for the evaporator defrosting phase.

For an installation with underfloor heating/cooling (water flow/return temp.: + 18 °C/+ 23 °C), the cooling output is limited but sufficient to maintain comfortable conditions in the home. This allows the room temperature to be reduced by 3 to 4 °C on average.

-sizing the buffer tank

- The volume of water contained in the heating system must be able to store all the energy supplied by the heat pump during its minimum operating period. Consequently, the buffer volume corresponds to the minimum water volume demand, from which the network capacity is subtracted. It is recommended to install a buffer tank for installations whose water volume is less than 5 l per kW of the heat pump's heat output (take into account the water volume of the MIC).
- Increasing the volume in an installation limits compressor short cycle operation (the higher the water volume, the fewer compressor start-ups will be required, thus extending its service life).
- In the first instance, below is an estimate of the buffer volume for a minimum operation time of 6 minutes, a control differential of 5 K and a negligible network volume (take into account a water volume in the MIC of 5 litres).
- The buffer tank should be installed on the heating circuit return. If there are 2 heating circuits, the buffer tank should be installed on the return of the circuit with the lowest water volume.

rules for calculating the buffer volume

The following two rules can be used to estimate the buffer volume associated with an installation:

- Installation with underfloor heating: 6 litres/kW
- Installation with radiators or convection fans: 5 litres/kW

minimum volume (litres) in a heating installation according to the model

HEAT PUMP MODEL	INSTALLATION WITH UNDERFLOOR HEATING	INSTALLATION WITH RADIATORS	INSTALLATION WITH CONVECTION FANS
STRATEO 4.5 MR/E	26	22	20
STRATEO 6 MR/E	29	27	26
STRATEO 8 MR/E	57	47	44

-sizing the expansion vessel

The STRATEO includes a 12-litre expansion vessel as standard. Make sure that the expansion volume is sufficient based on the installation configurations. A sizing tool is available on the PRO site in DiemaTOOLS.

WARNING

An oversized expansion vessel can cause air to infiltrate the heating circuit, which can substantially impair the installation's service life.

MAGNETIC FILTER

The **magnetic screen filter** is a safe, durable technical solution which guarantees that our heat pumps continue to run smoothly over the long term. **All our heat pumps** and hybrid systems **are equipped ex works** with a brand new filter designed by Caleffi and specifically adapted to our products.

This filter comprises a screen with a collection surface area three times larger than a conventional screen filter, and a magnetic bar with a very large capacity to retain all the types of particles which may be found inside the heating network. It also acts as a **sludge container** and has a built-in **drain valve**; the back of the cap can be used to drive out the residue it has collected

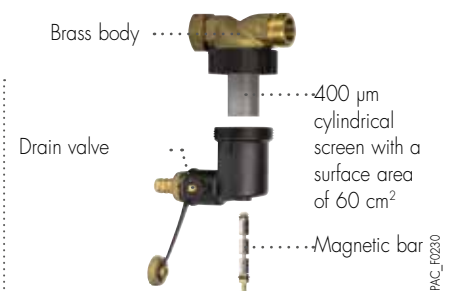

IMPORTANT

Even when this filter is fitted, it is still important to adhere to good industry practice as concerns installing and commissioning. The filter is quick and easy to clean, and this must be performed during each annual maintenance and if the flow rate is insufficient. Please respect the specifications required for the heating water indicated in the manual. Any infiltration of air into the hydraulic circuit is prohibited. It is important to ensure the expansion vessel is correctly sized and that its inflation pressure is correct.

INSTALLATION EXAMPLES

STRATEO

The examples shown below cannot include all of the possible installation scenarios encountered. They are intended to draw attention to the basic rules to be respected. A certain number of safety and control components are shown, but final responsibility for which safety and control components should definitively be provided in the boiler room, based on its individual requirements, lies with the planners, consultant engineers and design offices. In every case, it is important to comply with the applicable regulations and adhere to good industry practice.

STRATEO 4.5 MR/E HEAT PUMP

- 1 direct underfloor heating circuit on the manifold
- controlled by 1 SMART Tc° connected room thermostat

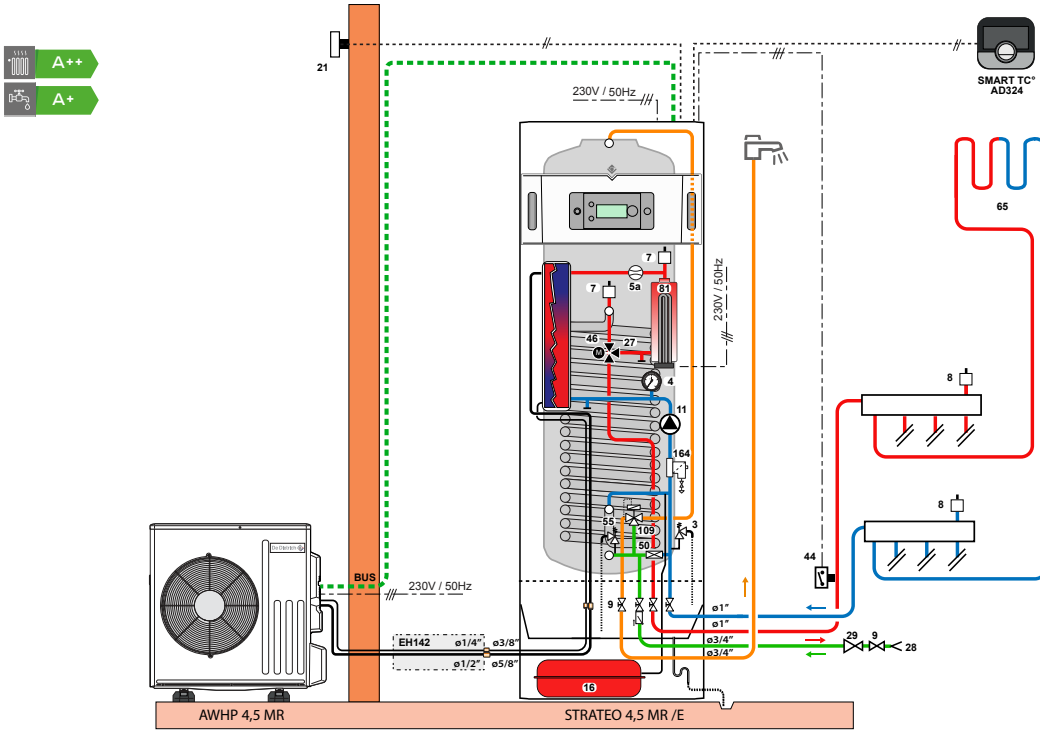

STRATEO_IF006

STRATEO 4.5 MR/E HEAT PUMP

- 1 parallel radiator circuit
- controlled by 1 SMART Tc° connected room thermostat

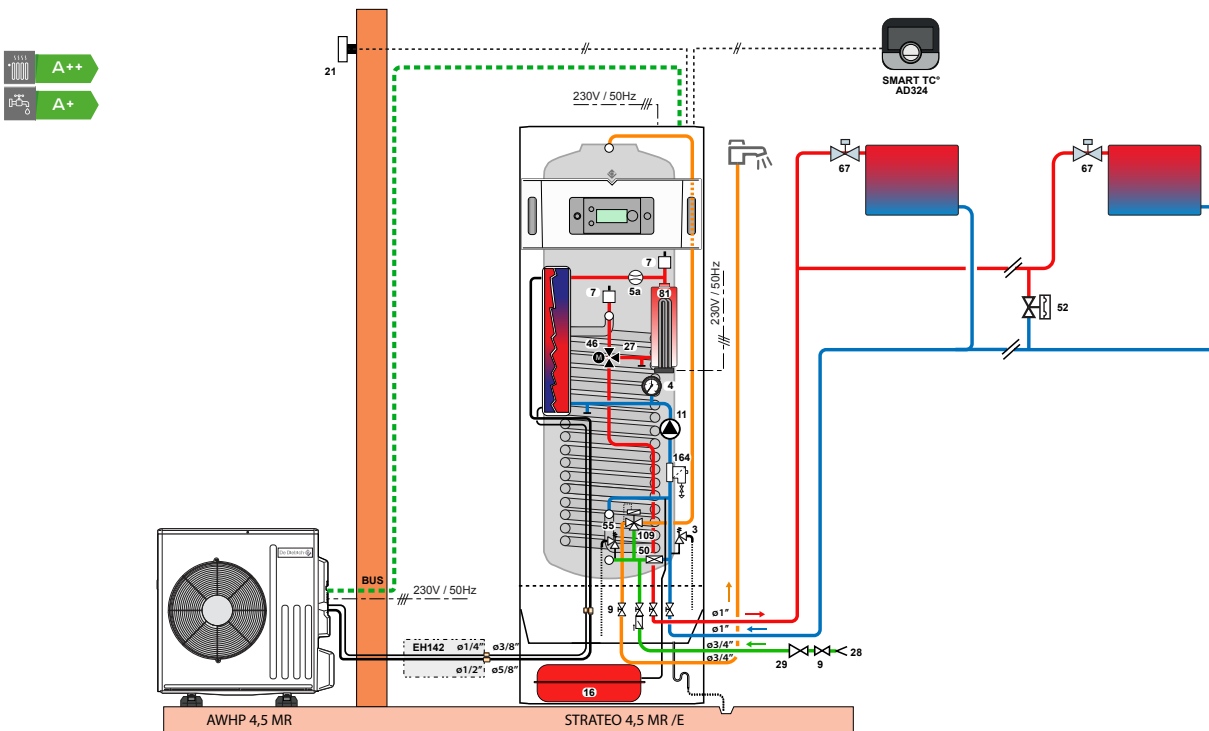

STRATEO_IF007

KEY: see page 30

INSTALLATION EXAMPLES

STRATEO

STRATEO 8 MR/E 2C HEAT PUMP

- 1 radiator circuit with manifold
- 1 underfloor heating circuit with mixing valve
- Each controlled by 1 SMART TC° connected room thermostat

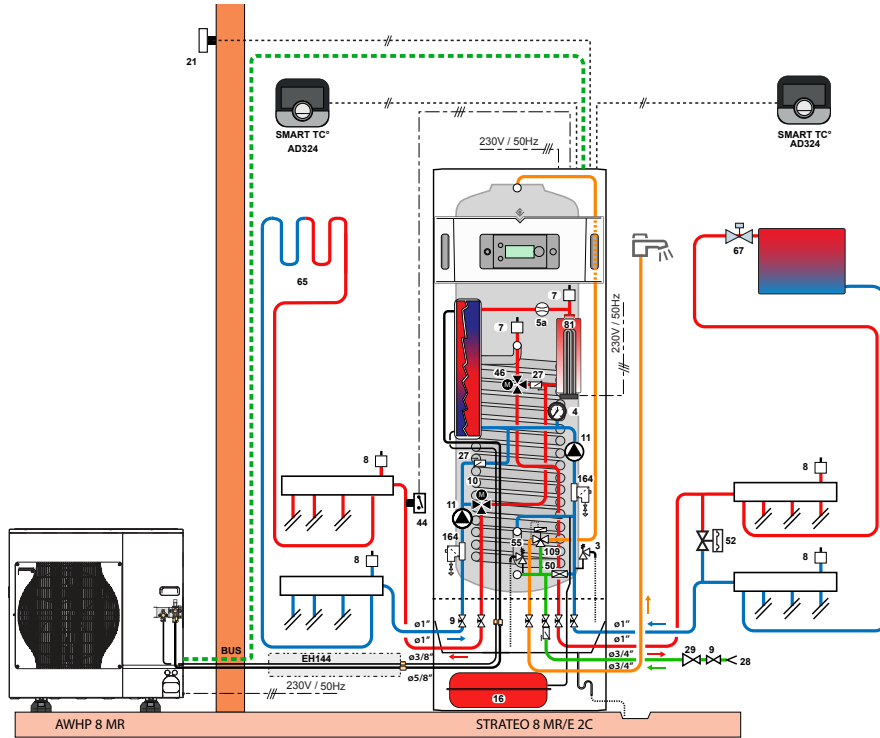

STRATEO_IF003

STRATEO 8 MR/E 2C HEAT PUMP

- 1 underfloor heating circuit on direct circuit
- 1 underfloor heating circuit on mixed circuit
- Each controlled by 1 SMART TC° connected room thermostat

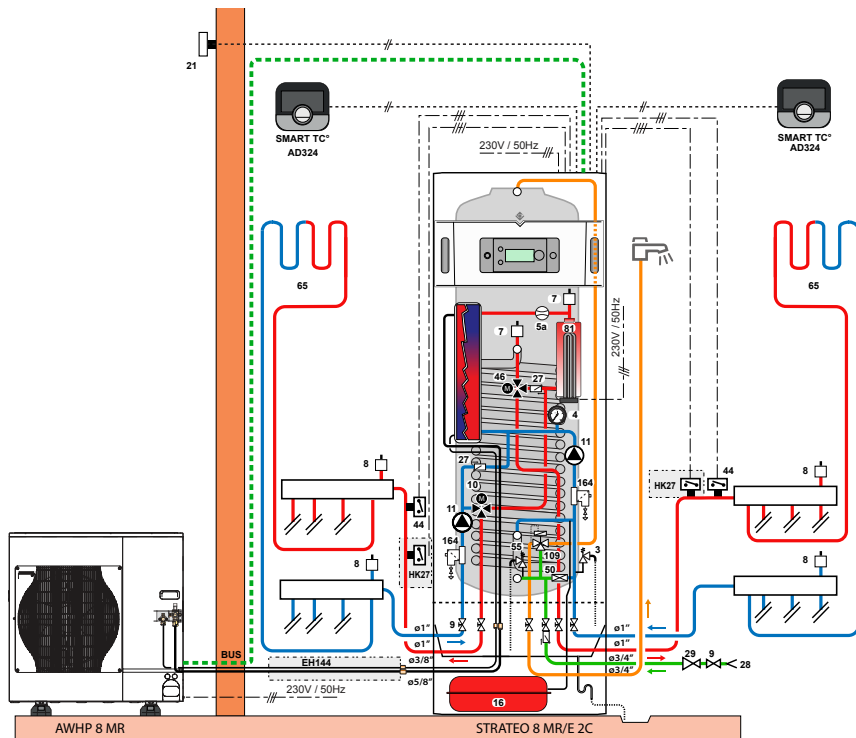

STRATEO_IF023

Connection of the 2 safety thermostats (not supplied)

- With HA255 on the direct circuit circulating pump
- Connection to SCB-04 (TS terminal block) for the mixed circuit

For cooling on both floors

- Add 1 HK27 sensor to the flow for each circuit
- Parallel connection of both sensors to the "CONDENSATION" terminal block
- Modify the AP072 parameter: sensor type, change from 0 to 1

KEY: see page 30

INSTALLATION EXAMPLES

STRATEO

STRATEO 8 MR/E 2C HEAT PUMP

- 1 radiator circuit with low-loss header
- 1 underfloor heating circuit with mixing valve
- Each controlled by 1 SMART TC° connected room thermostat

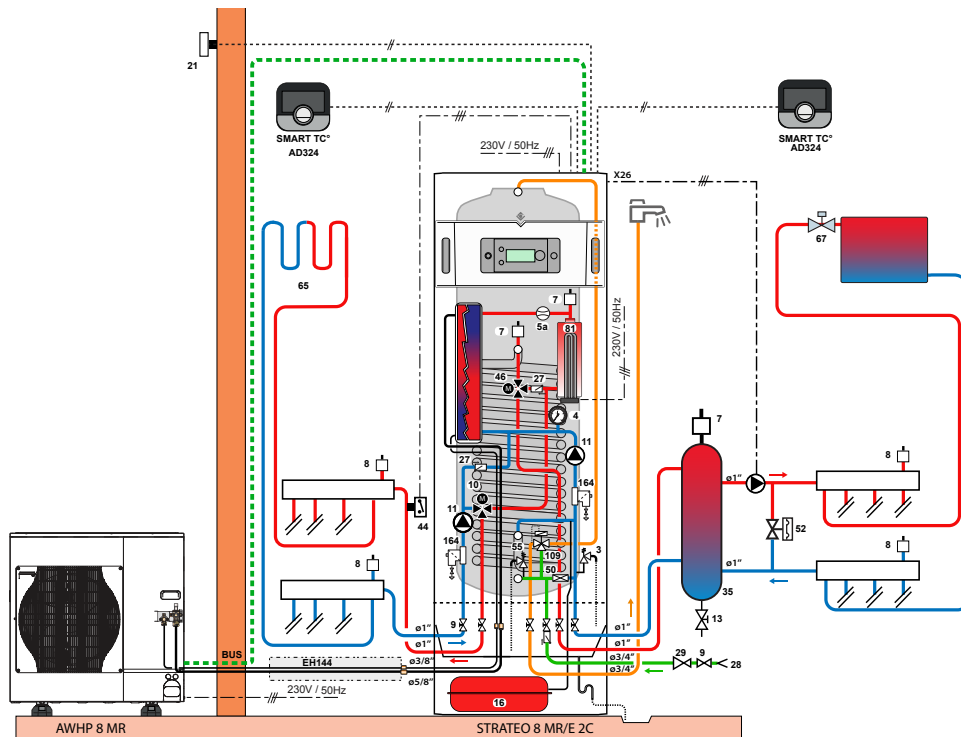

STRATEO_F0008

STRATEO 8 MR/E 2C HEAT PUMP

- 1 radiator circuit with manifold
- 1 underfloor heating circuit with mixing valve
- Each controlled by 1 SMART TC° connected room thermostat
- with outlets on one side (left or right)
- routing of the DHW behind the product in the corner (routing of up to 2 tubes on each side)

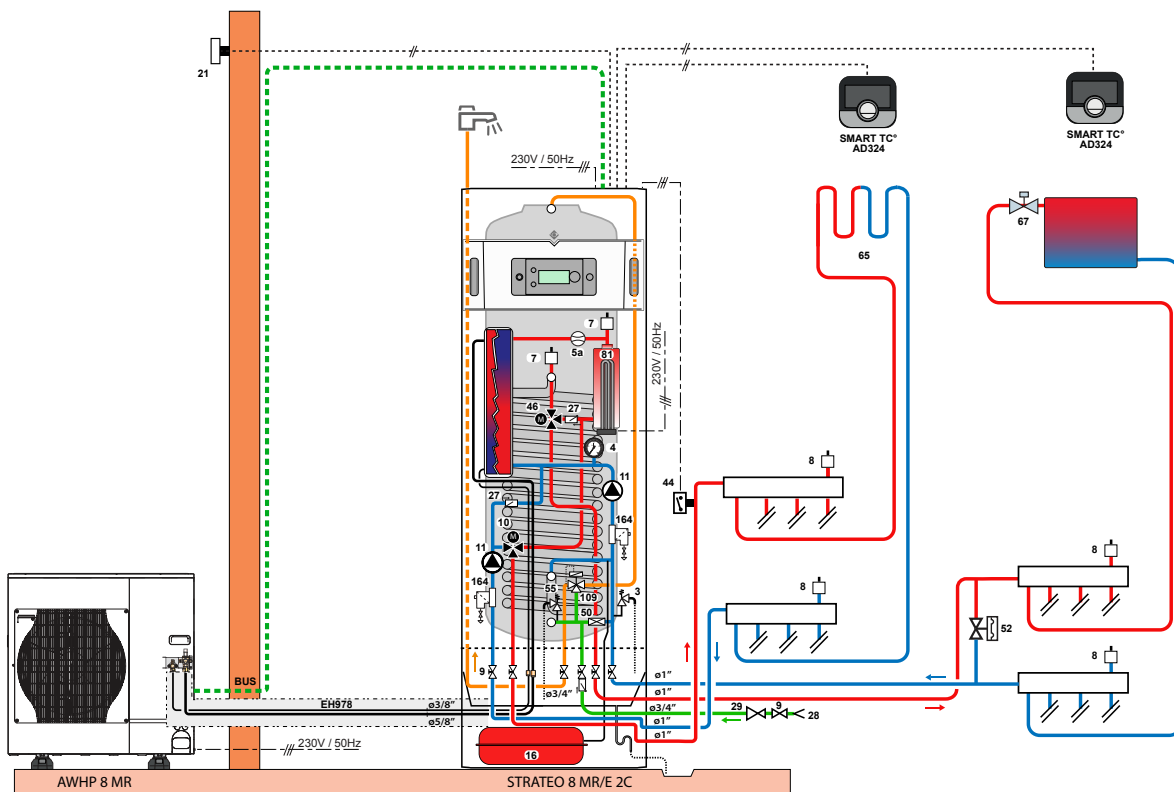

STRATEO_F0009

KEY: see page 30

INSTALLATION EXAMPLES

STRATEO

STRATEO 4.5 MR/E HEAT PUMP

- 1 direct underfloor heating circuit
- Each controlled by 1 SMART TC° connected room thermostat

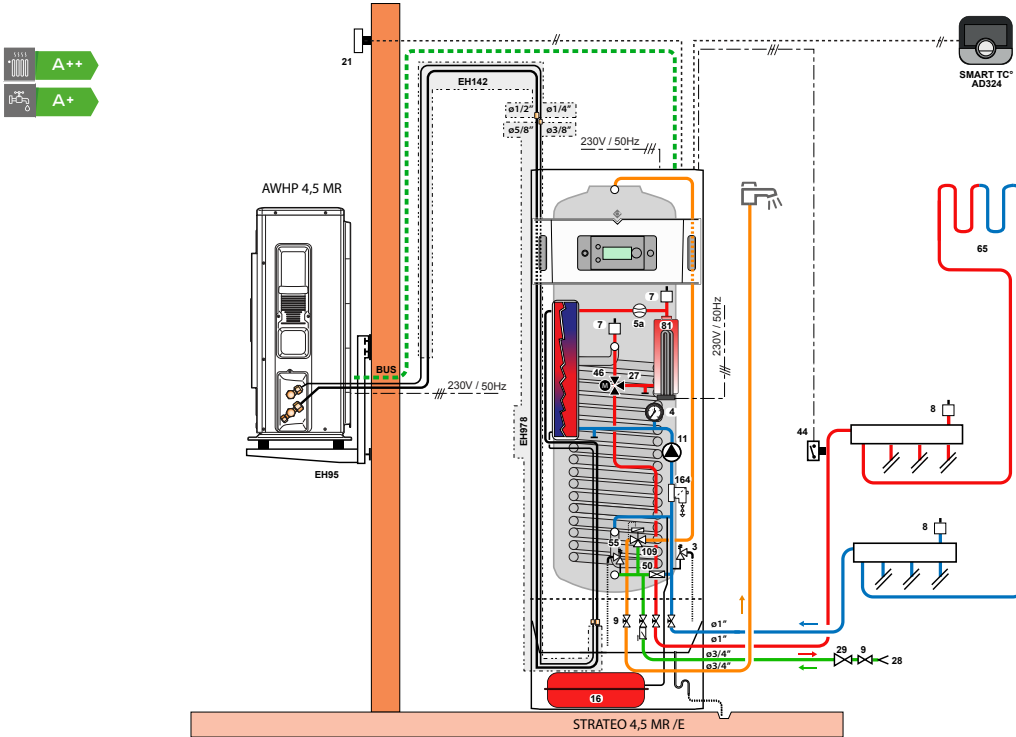

KEY

- | | | | | | | | |
|----|----------------------------|----|----------------------------|----|--|-----|---|
| 3 | 3-bar heating safety valve | 13 | Drain valve | 44 | 65 °C safety thermostat with manual reset for underfloor heating | 67 | Radiator heating circuit thermostatic valve |
| 4 | Pressure gauge | 16 | Expansion vessel | 46 | DHW reversing valve | 81 | Back-up immersion heater |
| 5a | Flow controller | 21 | Outdoor temperature sensor | 50 | Disconnecter | 109 | Thermostatic valve |
| 7 | Automatic air vent | 27 | Non-return valve | 52 | Differential valve | 117 | Three-way reversal valves |
| 8 | Manual air vent | 28 | Domestic cold water inlet | 55 | 7 bar domestic safety valve | 164 | Magnetic filter |
| 9 | Stop valve | 29 | Pressure reducer | 65 | Underfloor heating circuit | | |
| 10 | Mixing valve | 35 | Low-loss header | | | | |
| 11 | Heating circulating pump | | | | | | |

STRATEO_f000

Empty rectangular box for notes.



DE DIETRICH – HEAT PUMP MANUFACTURER SINCE 1981

Heat pump indoor units 100% manufactured in France.

The international heat pump Research & Development centre is based in the French city of Mertzwiller.

Since 2015, De Dietrich has owned the leading COFRAC accredited manufacturer's laboratory for thermal and acoustic performance in Europe.



Important recommendations

To guarantee the best performance from the heat pumps for optimised comfort and to maximise their service life, they must be installed, commissioned and maintained with due care. Comply with the instructions in the manuals provided with the appliances.

De Dietrich also offers heat pump commissioning in its catalogue. It is also strongly recommended that you sign a maintenance contract.



De Dietrich ECO-SOLUTIONS give you the latest generation of multi-energy products and systems: simpler, more efficient and more economical to guarantee your comfort and protect the environment.

The energy label associated with the ECO-SOLUTIONS label indicates the product performance.

www.ecodesign.dedietrich-heating.com



De Dietrich

BDR THERMEA France

Simplified joint stock company (SAS) with share capital of €229,288,696 €

57, rue de la Gare - 67580 Mertzwiller

Tel. +33 3 88 80 27 00 - Fax +33 3 88 80 27 99

www.dedietrich-thermique.fr